

CTS SUSPENDED

Field ready when you're ready

Designed to increase field access, stability and ride comfort. The best choice for combines facing the toughest conditions.

36Q23MA

Track width	36"
Track system height	65"
Track system length	104"
Flat plate area per pair (in ²)	5,285

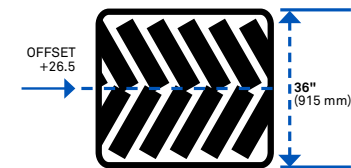
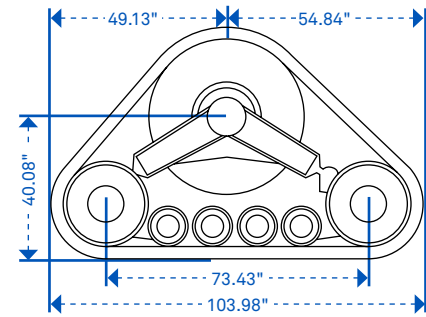

36" wide track

Main frame

Resulting in smoother ride and less wear on equipment and operators

- Suspended upper and lower frame design with rubber isolation

Only applicable for CTS High Speed and CTS Suspended

Suspension

Improves ground contact on uneven terrain, which helps transfer power to the ground

- Improves machine stability and header placement
- Patented double oscillating bogie wheels

Only applicable for CTS High Speed and CTS Suspended



OPTIONAL SPEED MULTIPLIER

Optional on 36Q track systems

- 30% faster roading speed out of your CTS
- Heavy duty gear box design
- 100% bolt-on feature that mounts between track system and final drive

Hydraulic tensioning system

Maximizes tractive performance and keeps sprocket and lug at optimum contact to extend track life

- Hydraulic tensioning system with nitrogen-charged accumulator

Wheels

Simplifies maintenance operations

- Heavy-duty wheels hubs with oil bath lubrication
- No greasing or repacking of bearings

Track

Large footprint that offers over 65% reduction in ground pressure

- Increases mobility on soft ground conditions

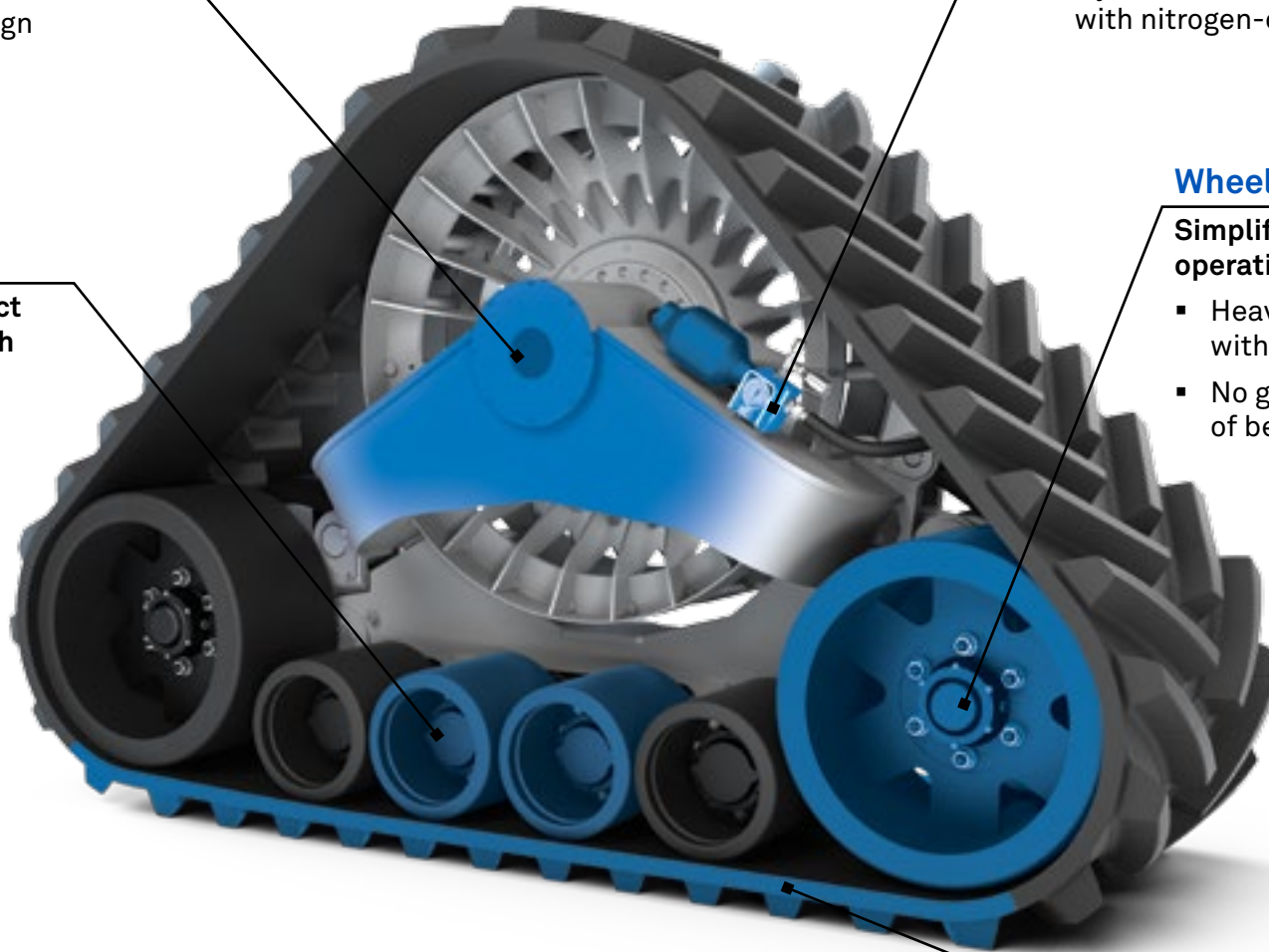

CTS STANDARD

More access to fields for maximum yields

Designed to increase field access and stability in soft ground conditions.

36T23A

Track width	36"
Track system height	64.6"
Track system length	104.3"
Flat plate area per pair (in ²)	5,309

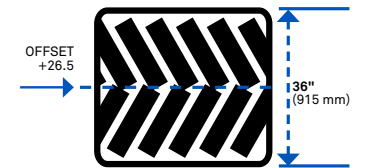
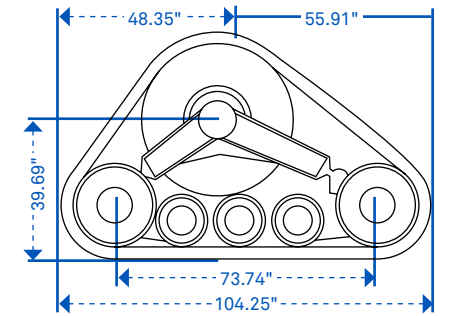

36" wide track

COMBINE APPLICATIONS

CONVERSION TRACK SYSTEM FOR COMBINES

NEW

CAMSO CTS HIGH SPEED

Faster roading speeds, more performance

The industry's first 100% bolt-on track system for combines with an integrated final drive system to achieve similar roading speeds to wheeled combines.

PERFORMANCE SPEED

FLOTATION

RIDE QUALITY



CAMSO CTS SUSPENDED

Field ready when you're ready

Designed to improve ride quality and achieve maximum ground contact.

PERFORMANCE SPEED

FLOTATION

RIDE QUALITY

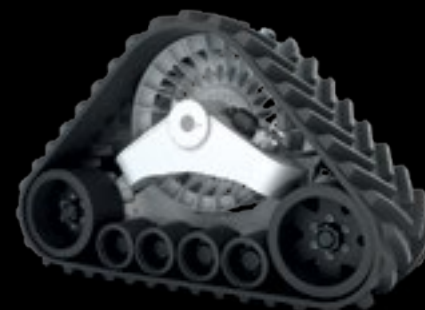

CAMSO CTS STANDARD

More access to fields for maximum yields

Designed to increase field access and stability in soft ground conditions.

PERFORMANCE SPEED

FLOTATION

RIDE QUALITY

