

OWNER'S MANUAL

2023

CAMSO UTV 4S1 TRACK SYSTEM
FOR SIDE-BY-SIDE VEHICLES



1099-01-1153





⚠ WARNING

Please read carefully each part of this document as well as model specific Installation Guidelines prior to assembling, installing and using the Track System.

CAUTION: The UTV 4S1 Track System by Camso is first and foremost designed to provide the best performance in terms of traction and floatation in conditions of extreme terrain such as deep snow and mud. The Track System is also designed for side-by-side type vehicles that can ride at a maximum speed of 40 km/h (about 70 km/h on the speedometer). Exceeding this speed when the terrain conditions are dry can cause premature wear and or major breakdowns on the Track System. If breakage occurs due to excessive speed, damage will not be covered under normal warranty. It is the user's responsibility to abide by these terms of use.

CAUTION: Longevity of the Camso UTV 4S1 Track System components is directly linked to the way the System is used. Sportive driving, rapid direction changes and repeated fast turns (especially on power steering vehicles) are not advised. These driving styles increase the risk of derailing and can cause premature wear and/or major breakdowns on the Track System which will not be covered under normal warranty.

Camso inc.
4162, rue Burrill - Local A
Shawinigan, QC G9N 0C3
CANADA

TECHNICAL SUPPORT

If your dealer or distributor is unable to solve a problem related to the System, you may contact the Camso support team from Monday to Friday.

E-Mail: pws.tracksystem@camso.co
Website: www.camso.co

System Serial Number: 6522NTA _ _ _ _

Original notice

Translations in other languages available at www.camso.co

TABLE OF CONTENTS

| | |
|---|----|
| INTRODUCTION | 1 |
| SYMBOLS AND SIGNAL WORDS | 1 |
| GENERAL INFORMATION | 1 |
| SERIAL NUMBER LOCATION | 1 |
| SAFETY | 2 |
| OPERATING INSTRUCTIONS | 4 |
| SPECIFICATIONS | 10 |
| ADJUSTMENTS | 11 |
| ANGLE OF ATTACK - FRONT TRACK SYSTEMS | 11 |
| ANGLE OF ATTACK - REAR TRACK SYSTEMS | 13 |
| ALIGNMENT | 15 |
| RUBBER TRACK TENSION | 17 |
| TRACKS - INSTALLATION DIRECTION | 18 |
| STORAGE | 18 |
| MAINTENANCE | 19 |
| LUBRICATION | 22 |
| WEAR | 26 |
| 2-YEAR LIMITED WARRANTY | 28 |
| TROUBLESHOOTING | 29 |
| "CE" DECLARATION OF CONFORMITY | 31 |
| ENVIRONMENT | 32 |
| PATENTS | 32 |
| TRACK SYSTEM VIEWS | 32 |
| TORQUE SPECIFICATIONS | 33 |

INTRODUCTION

Welcome to the Camso family!

Thank you for choosing our Track Systems to make your ride a new beast. Our products are designed to take you further and help you work harder in all terrain, whether you're hunting, ice fishing, caring for your land, reaching your remote cabin, or taking on any outdoor adventure. No matter where or in what conditions, get there and back safely with your Camso track systems.

Ready to benefit from optimal traction, mobility, stability, and flotation?

Let's go make tracks!

SYMBOLS AND SIGNAL WORDS

This guide uses the following signal words and symbols to emphasize particular information:

| |
|---|
|  WARNING |
| Indicates a potentially hazardous situation which, if not avoided, could result in death or serious injury. |

CAUTION: Indicates a potentially hazardous situation which, if not avoided, may result in damage to vehicle and Track System components.

NOTE: Indicates supplementary information.

 The Prohibition Safety Sign indicates an action NOT to be taken in order to avoid a hazard.

GENERAL INFORMATION

- All figures, information or photos presented in this document are up to date at the time of publication. However, they may change without notice. For the latest available version of this document, go to Camso's website: www.camso.co
- Read and follow indications of the SxS user manual and installation guidelines carefully. Their contents remains applicable after installation of the System.
- This document should be read by every person who drives the SxS equipped with the System.

- This document is an integral part of the System. Pass it along to any new System owner.
- Before usage, consult the legal authorities of the area where you operate your vehicle equipped with the System to ensure that all applicable laws and regulations are observed.
- SxS Track Systems are designed to reduce ground pressure and increase vehicle traction. However, during normal operating conditions, vehicle speed should be reduced compared to a wheeled vehicle.

SERIAL NUMBER LOCATION

The following figures show the location of the serial numbers on the Track System frame (Figure 1) and rubber track (Figure 2).

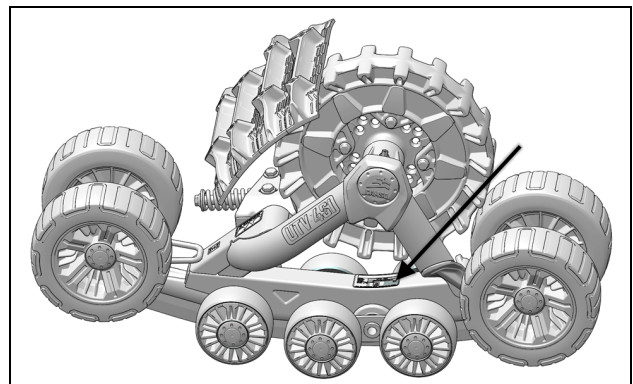

Figure 1

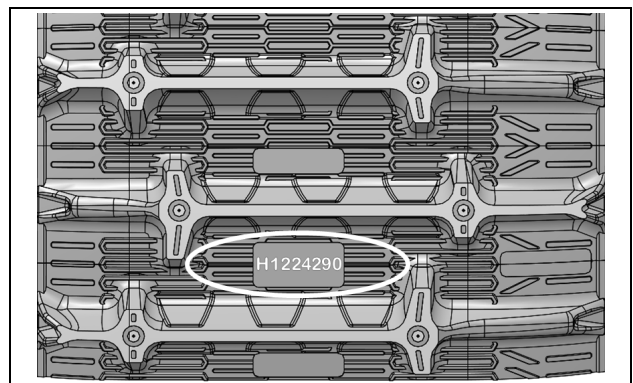
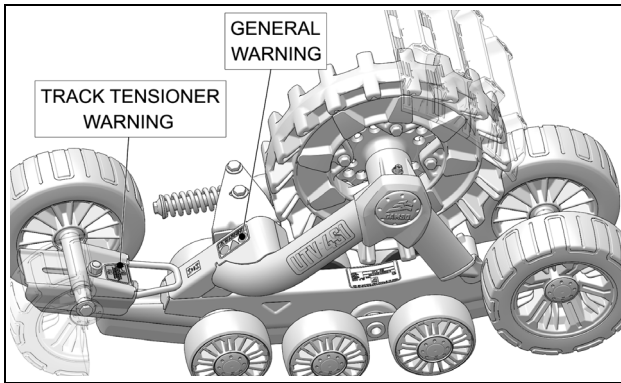

Figure 2

SAFETY

WARNING STICKERS

You will find on Track System frames the warning stickers shown in the illustration below. Read the stickers carefully and understand them before using the Track Systems. They contain important information about safety and proper operation of the Track Systems.



CAUTION: Do not remove the warning stickers from the frame. If a sticker is damaged, have it replaced by an authorized Camso dealer.

GENERAL WARNING



User Manual - Users must read the *User Manual* before attempting to operate a vehicle equipped with Track Systems.



If Track Systems are sold or in any way transferred to a new user, the *User Manual* must also be transferred to the new user.



Moving Parts - Hands or fingers caught between moving parts of the equipment present a danger to life or limb. Turn motor off before servicing Track Systems.



Maintenance Schedule - Follow instructions contained in the Maintenance Schedule section of the *User Manual* to ensure safe and long-lasting operation of Track Systems.

TENSIONER WARNING

Tensioner Bolt Warning - If track tension adjustment is required, the tensioner assembly bolt must be loosened first. Re-tighten the bolt to the recommended torque specification after completing the tension adjustment.



POSITION PICTOGRAM STICKERS

These labels indicate the position of each Track System: front left, front right, rear left and rear right. They are located on the frame.

Front left



Front right

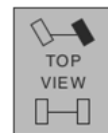

Rear left



Rear right



USER NOTICE AND DISCLAIMER

The **Camso UTV 4S1** System was initially designed to be used in winter conditions and was then adapted to be used in fall and spring conditions.

This document holds important information regarding driving an SxS equipped with the **Camso UTV 4S1** System by Camso. It is mandatory that every user takes the time to carefully read, understand and then consult this reference manual and user guide as well as the SxS owner's manual as needed. When purchasing either a new or used Track System, the user must obtain all documentation related to the System, including manuals and guides related to the SxS on which the System is installed. If need be, contact the Camso products dealer nearest to you to obtain any additional information. You may also consult the Camso Web site at www.camso.co and contact our technical support by email at pws.tracksystem@camso.co

Camso believes that there are certain risks related to the installation and use of the System. Our experience shows that the System is safe. However, the user must be aware of the risks related with driving a SxS with the particularities of this type of System. The SxS driver must, at all times, respect all applicable laws and regulations, the indications of the System manufacturer and the indications from the vehicle manufacturer fixed by law, namely when age restrictions exist and SxS base equipment is required (headlights, flashers and brake lights, rear view mirror, etc.). The user must always wear adequate safety equipment, such as a helmet, safety glasses (or visor), protective clothing, boots and gloves. It is understood that driving while impaired or intoxicated presents a danger for the SxS user and others and is against the law.

The System consists of many moving parts, including transmission wheels. If an object lodges itself or becomes jammed into the System and blocks the track, it is mandatory to stop the engine and the vehicle and apply the security brake before removing said object. By avoiding to do so, the user exposes himself to sudden movement of the SxS or to breakage of a part or component coming from the System, which could cause severe injuries. It is also very important to wear full length clothing and always avoid hanging or stringy accessories.

Driving a SxS equipped with such a System requires particular precautions and a knowledge of proper driving techniques of such vehicles. An evaluation by the user of the conditions and terrain (state of the ground, grade of hill, density of snow, etc.) is equally essential.

A SxS equipped with a System cannot compete and/or be used to perform stunts, acrobatics or other exploits, as these could result in loss of control or severe injuries.

Insufficient knowledge of a SxS during down hill riding, climbs and crossing of obstacles and turns can result in tipping or roll over, and can cause severe injuries.

Carrying a passenger, a load or attaching a tow can cause the SxS to be less stable, and affect vehicle usability. Unless otherwise prescribed by law and by the SxS manufacturer, you must not carry a passenger, loads or tow any objects.

The installation of a System:

- Increases ground clearance.
- Changes the center of gravity.
- Increases the SxS width and weight.
- Reduces ground pressure.

These parameters will effectively change driving characteristics of a SxS equipped with the System.

Consequently, **it is highly recommended that the user adapt his driving style to the new characteristics mentioned above.** The driver must always use caution when he crosses obstacles, circulates through narrow paths, meets vehicles coming in the opposing direction, etc.

As it was designed, the System will considerably reduce the SxS top speed and can falsify the speedometer. Generally, the System transmission wheel diameter is less than that of the tire. Therefore, the vehicle speed will be less than that actually displayed. Whether the SxS is equipped or not with the System, users must always adapt the speed to actual driving conditions. Users must never exceed speed limits or drive faster than their capacities allow. Excessive speed remains one of the main causes of severe accidents on SxS.

Camso is proud to offer SxS conversion kits within its wide range of products. SxS Track Systems are not only reliable, but safe. However, there are risks inherent to driving a SxS equipped with the System. It is therefore very important that any driver familiarizes himself with proper driving techniques of a SxS equipped with a System, and that he adapts his driving to his level of experience and continually evaluates operating conditions and terrain to safely and efficiently make the best of these Camso SxS Track Systems.

OPERATING INSTRUCTIONS

HINTS AND TIPS

- Before leaving for an excursion, make sure to bring with you the following: 13 mm, 15 mm, 16 mm, 17 mm, and 19 mm wrenches and sockets, an ax, a shovel, a tow cable, a lifting jack and an adjustable wrench.
- Generally, the slower you go, the better the traction will be.
- For riding on excursions on unknown or remote terrain, make sure to have a cellular phone or satellite phone, a first aid kit and spare parts in your possession.
- When driving off trails, always be cautious of hidden obstacles that could be present.
- When driving in deep snow, do not intentionally spin the tracks (tracks keep turning without the vehicle moving). It could cause the vehicle to get stuck.

BREAK-IN PERIOD

CAUTION: A break-in period is necessary to allow the components of the system to settle and adjust themselves to each other.

During the break-in period (4 hours or 80 kilometers), follow these recommendations:

| VERIFICATION | Hr 0 | Hr 1 15 km/h* | Hr 2 25 km/h* | Hr 3 35 km/h* |
|-------------------------------|------|------------------|------------------|------------------|
| Visual Inspection | x | x | x | x |
| Track Tension | x | x | | |
| Angle of Attack | x | x | | |
| Alignment | x | | | x |
| Bolt Torque - Anchor Brackets | | | | x |

* Maximum Real Speed

CAUTION: Avoid running under dry and clean conditions. (For example: asphalt, hay or straw field, etc). Start sharp turns at very low speed: (10 km/h maximum real speed).

- A **GOOD** break-in period must be done in a lubricated environment such as water, mud, snow, soft soil, sand, dust, etc.

- A **BAD** break-in period can generate smoke, odors of burned rubber as well as plastic deposits on the sprocket and/or the frame.

⚠ WARNING

Driving a vehicle equipped with a Track System is different from driving a vehicle on wheels. It is strongly recommended that the safety guidelines provided below be followed to prevent any accident or serious malfunction that could affect the occupants, the vehicle or the Track System.

CAUTION: Non-compliance with usage recommendations can lead to a warranty claim refusal.

PRE-USE VERIFICATION

CAUTION: Before each ride make sure that the System's wheels and moving parts are free and that they are not frozen or stuck on the frame.

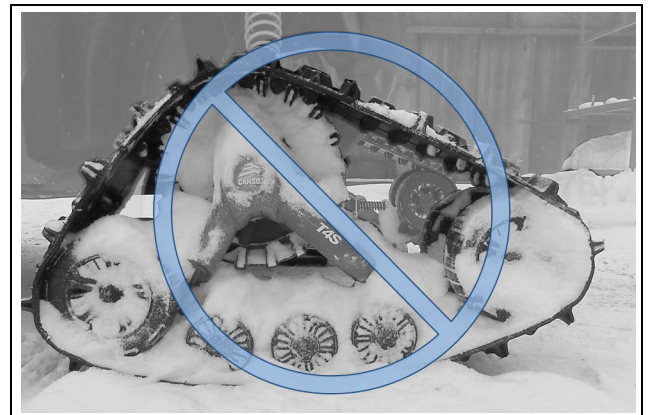

CAUTION: Track systems installed on a SxS vehicle project more snow, dirt, water, or mud than tires. The owner/driver is responsible for adapting engine and CVT air intakes to minimize the risks of breakdowns and/or damage to mechanical components.

STEEP DESCENTS

CAUTION: It is not advisable to change direction during steep descents. This can lead to a serious malfunction of the SxS's steering system and Track Systems.



CAUTION: During a steep descent, it is advisable to keep the handlebars straight and to begin turning when the SxS is on flat ground, thus avoiding subjecting the vehicle components and the System to any high stress.



DESCENDING AND BEING STUCK IN REVERSE

CAUTION: If the rear Track Systems get stuck in the snow, avoid moving or towing the vehicle in reverse to ease it from its position, as this could lead to a malfunction of the Systems. If possible, move it in the forward direction to free it from the snow.



CAUTION: It is advisable to remove the snow from the top of the rear Track Systems and to compact it behind the Systems, using your feet, to dislodge the track. Shoveling remains the best alternative in this situation.



DRIVING OVER AN OBSTACLE TALLER THAN 30 cm [12 in]

CAUTION: It is not advisable to attempt to drive over an obstacle taller than 30 cm [12 in], such as a tree trunk, stump or big rock.



CAUTION: If the situation occurs, insert a log or a rock to lower the height of the obstacle and facilitate driving over the obstacle.



EXCEEDING THE ANTI- ROTATION STROKE ON ROUGH TERRAIN

CAUTION: Never exceed anti-rotation stroke of front or rear Track Systems. System or vehicle failure may occur. Camso recommends always riding on terrain that fully supports the Track System.

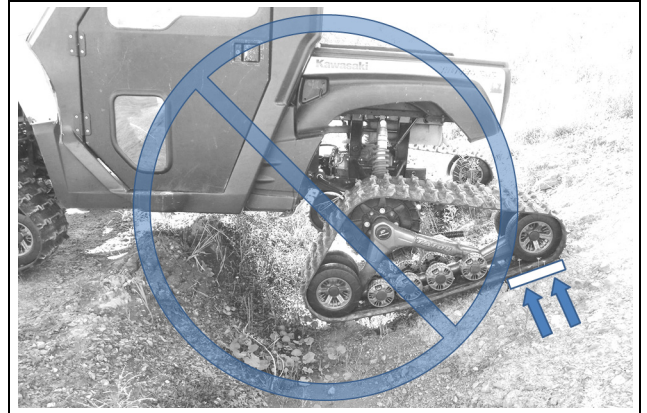

CAUTION: It is recommended to drive on a surface on which the Track System is always fully supported.

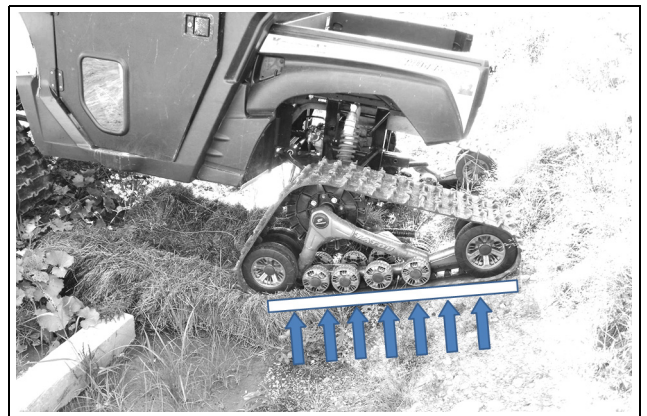

OPERATING INSTRUCTIONS

LOCATION OF TOWING CABLE

CAUTION: If your vehicle must be towed out of the snow, do not secure the towing cable on the Track Systems.

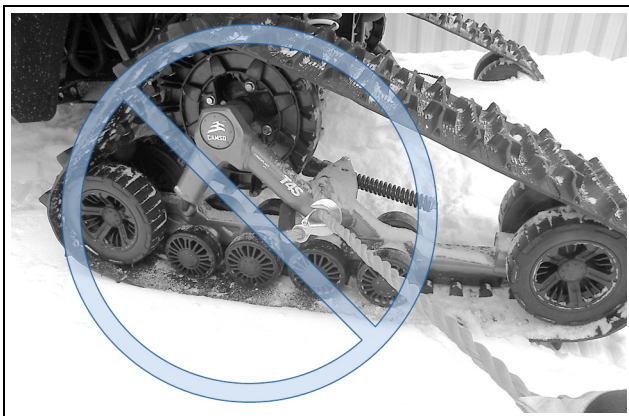

CAUTION: The towing cable must be attached to the vehicle's frame.

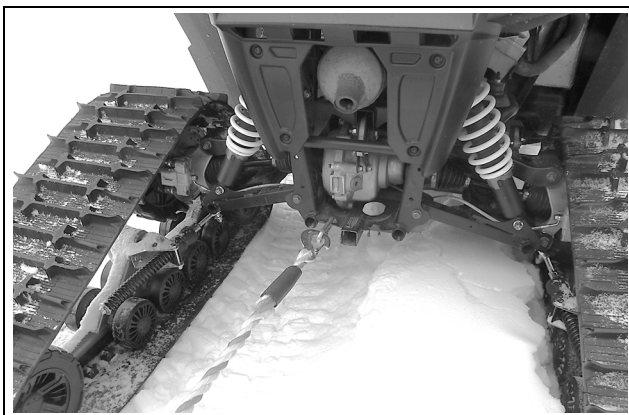

TOWING A VEHICLE OUT OF THE SNOW

CAUTION: If your vehicle must be towed out of the snow, never tow it in the direction in which you were going when the vehicle got stuck.



CAUTION: Tow the vehicle back in the direction of the tracks left before getting stuck.

TRACK SYSTEMS OPERATING IN WATER AND MUD

CAUTION: If Track Systems are used in wet conditions, submerged in water and/or mud, it is important to consult the Track System's maintenance chart and to observe the maintenance intervals indicated in this manual related to commercial, industrial and abrasive conditions use.



DRIVING OVER A STEEP RIDGE

CAUTION: It is not advisable to attempt to drive over an obstacle, such as a tree trunk, big rock or steep ridge that could lodge itself between the front and the rear Track Systems and immobilize the vehicle. The best option remains to bypass this type of obstacle.



SHARP TURNS IN LOCKED 4X4 MODE

CAUTION: Do not make sharp turns in locked differential 4x4 mode on sticky terrain without lubrication. The Track System is designed to slip into the drive system, keeping the vehicle from being overloaded.



DRIVING OVER AN OBSTACLE



NOTE: Some vehicles do not have a rear differential with unlocked 4x4 mode. These vehicles should avoid the situation described above and make wider turns instead.

DRIVING ACROSS SLOPES

⚠ WARNING

Driving across slopes can be dangerous. On a slope too steep, your vehicle could rollover. Keep in mind that mud, snow or ice can modify ground conditions. In all cases, do not drive across a slope with a bank angle of more than 15 degrees.

JUMPING

⚠ WARNING

Jumping with vehicles equipped with Track Systems is not recommended. These Systems were not designed to carry out this type of operation. A SxS equipped with the System must never be used for the following activities: races, rallies, jumps, stunts, acrobatics or any other extreme applications.

EQUIPMENT / ACCESSORIES

CAUTION: Some equipment / accessories such as snow plow, front bumper or side protective panels, may interfere with track systems. The owner must verify that contact does not occur and, if needed, adapt the vehicle to avoid potential interference.

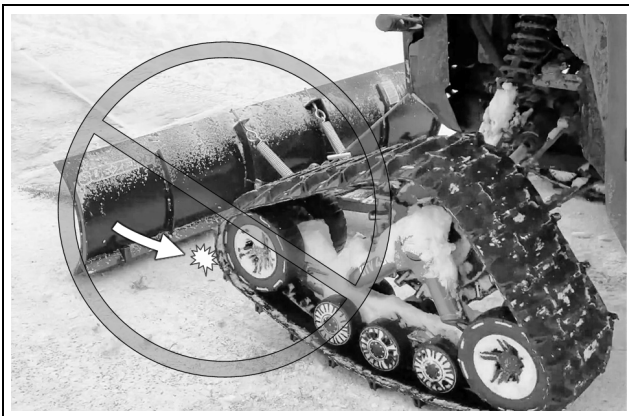

⚠ WARNING

Always follow the SxS manufacturer's safety rules and recommendations regarding, for example passengers transportation, maximum loads, etc.

⚠ WARNING

When travelling in groups, people following vehicles with Track Systems should be warned of potential dangerous objects that can be propelled by tracks. Be especially cautious on "rocky" trails.

⚠ WARNING

Allow for a greater braking distance and periodically apply the brakes while driving to prevent ice buildup on brake components.

⚠ WARNING

Adapt your driving style to surrounding conditions (weather, traffic, etc.) and your driving abilities.

⚠ WARNING

Drivers must remain vigilant and cautious at all times. Snow and mud can hide dangerous obstacles.

CAUTION: Reduce your speed at all times; Track Systems installed on a vehicle do not have the same absorption capacity as tires.

CAUTION: Always operate in 4x4 mode, this significantly reduces possibility of derailing in any conditions.

CAUTION: In loaded / working mode (100 kg and over), reduce significantly your speed and be extra careful on rough terrain.

CAUTION: Never exceed vehicle cargo and tow capacity specified by your vehicle manufacturer on any type of terrain.

CAUTION: the driver is responsible for following the recommended scheduled maintenance described in this manual.

SPECIFICATIONS

OFFSETS ON VEHICLE

Installation of a Track System on a vehicle creates offsets in length, height and width. The offsets are illustrated in the figure below and their dimensions are specified in the accompanying table.

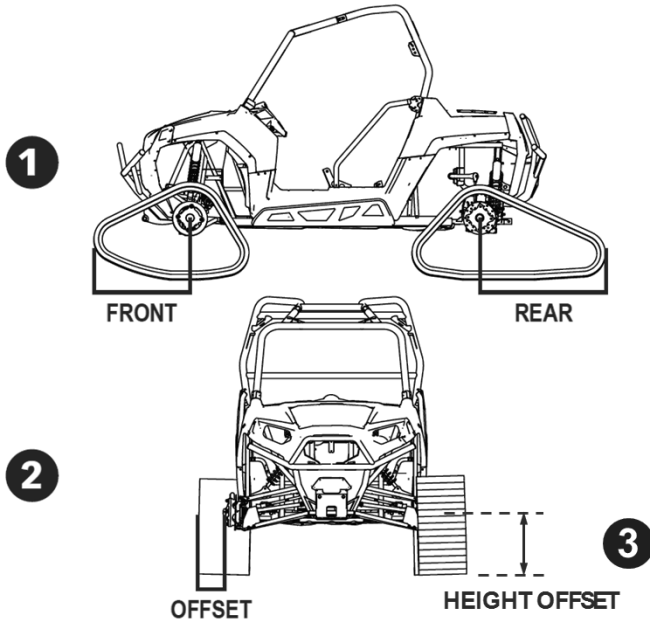

| | | | |
|---|--------------------|-----------------------|-------------------|
| 1 | OFFSET (length) | FRONT | 26,5 in. (673 mm) |
| | | REAR | 35 in. (889 mm) |
| 2 | OFFSET (width) | POLARIS | 8 in. (203 mm) |
| | | JOHN DEERE & KUBOTA | 7,5 in. (190 mm) |
| | | OTHER MODELS | 7 in. (178 mm) |
| 3 | OFFSET (height) | ORIGINAL TIRE: 26 in. | 3,5 in. (89 mm) |

TORQUE SPECIFICATIONS

The table below contains the recommended torque specifications according to bolt size and grade.

CAUTION: Some bolts in the Track System assembly have a specific torque specification. Refer to the exploded views at the end of the Manual to obtain the exact torque specifications applied to these bolts.

| DIMENSION | GRADE | Nm | lb-ft |
|-----------|-------|-----|-------|
| M6-1.0 | 8.8 | 10 | 7 |
| M8-1.25 | 8.8 | 25 | 18 |
| M8-1.25 | 10.9 | 33 | 24 |
| M10-1.5 | 8.8 | 50 | 37 |
| M10-1.5 | 10.9 | 70 | 52 |
| M12-1.75 | 8.8 | 90 | 66 |
| M12-1.75 | 10.9 | 125 | 92 |

NOTE: Use a thread locker (Loctite 262 type or its equivalent) at indicated places in the exploded views of the System.

SPEEDOMETER & TRIP METER READINGS

Our Track System affects the Speedometer and Trip meter readings. Generally, the System sprocket diameter is smaller than the tire diameter. As a result, real vehicle speed is less than that actually displayed by approximately 35%.

FUEL CONSUMPTION

A lower travelling speed and a higher revving engine will affect fuel consumption. A vehicle equipped with tracks will travel a shorter distance and will consume more fuel than compared to a vehicle operating on wheels.

ADJUSTMENTS

CAUTION: Track System adjustments must be verified after first use on the vehicle, and then at the maintenance chart's recommended intervals. Track tension, alignment and angle of attack of each Track System unit must be re-verified. Incorrect adjustments can decrease System performance and produce premature wear on certain components.

NOTE: To make the following adjustments, position the vehicle on a flat and level surface.

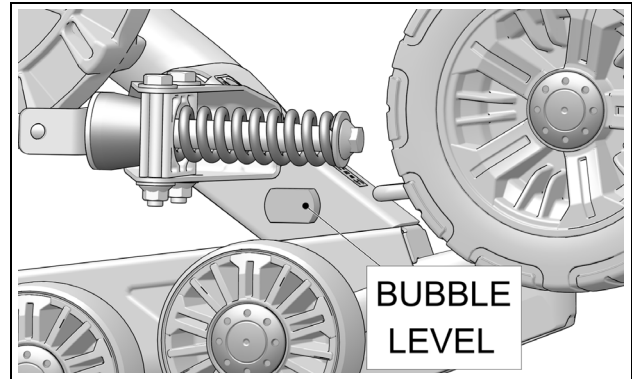

Figure 4

ANGLE OF ATTACK - FRONT TRACK SYSTEMS

To obtain the correct angle of attack on front Track Systems, perform the following:

- Orient the steering wheel and the Track Systems straight ahead
- Temporarily apply pressure to the front of the track to make sure that it stays flat on the ground
- Stabilizing arm (1) must be attached to the front anchor bracket (2) installed on the vehicle. See Figure 3.

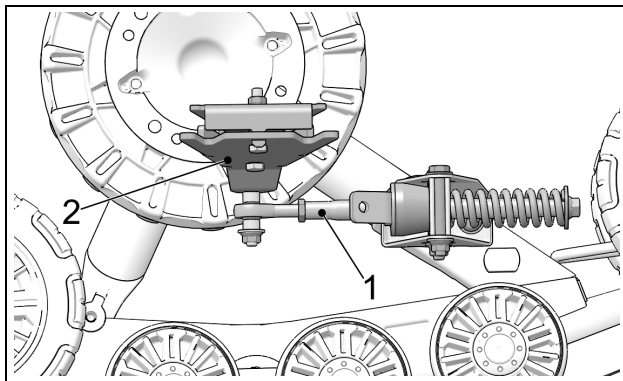

Figure 3

- A Bubble Level is attached to the inside of the front frames. A perfectly centered bubble is needed to adjust the angle of attack correctly. See Figure 4.

NOTE: Before each measurement, temporarily apply light pressure to the front of the track to make sure that it stays flat on the ground.

- Loosen anti-rotation bracket bolts (1) and (2) to allow the anti-rotation retainer (3) to rotate freely on its axis. See Figure 5.

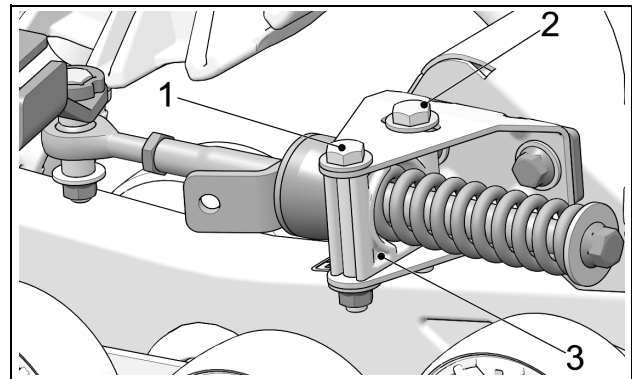

Figure 5

- Loosen jam nut (1). Adjust length of rod end (2) by rotating the steering limiter support plate on (3) the stabilizing arm. Use a 30 mm wrench to rotate support plate to obtain a perfectly centered bubble in the level. Figure 6.

NOTE: Stabilizing arms on front Track Systems incorporate a steering limiter support plate (3) that is bent. This plate should be positioned inwards, towards the vehicle.

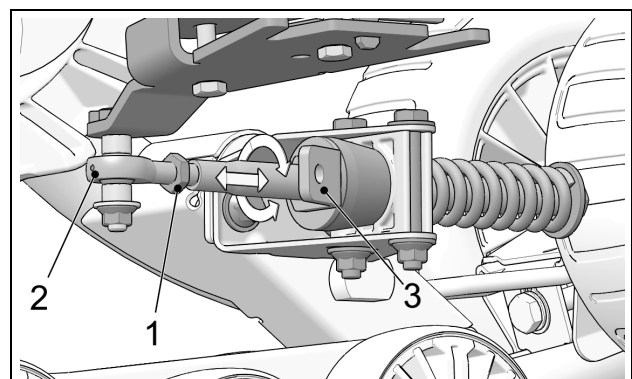

Figure 6

- When angle of attack is correctly set, tighten the jam nut (1) back against the stabilizing arm to 40 N•m [30lb•ft] of torque. See Figure 7.

CAUTION: Tighten jam nut to recommended torque specification. Overtightening nut might damage rod end.

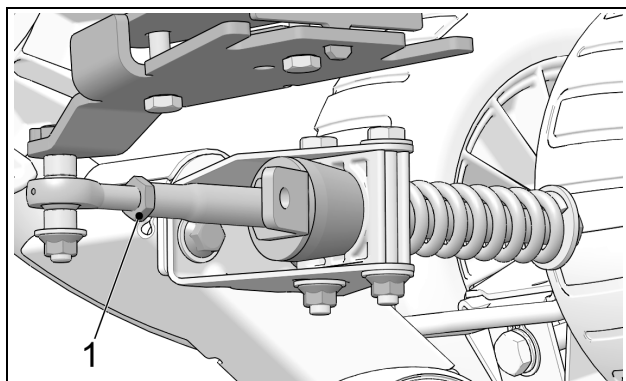

Figure 7

- Re-tighten anti-rotation bracket bolts (1) and (2) to 50 N•m [37 lb•ft] of torque. See Figure 8.

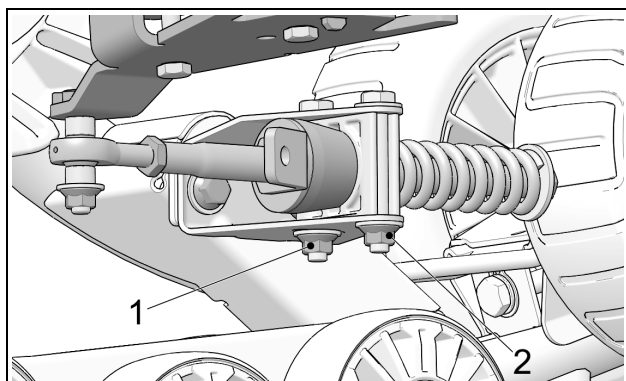

Figure 8

- Once the centered bubble in the level indicates that the angle of attack is correct, double-check the setting by validating the distance from the top of the back tires to the ground.

Position a flat bar on top of the rear wheels of the front Track System and measure from the ground up to the flat bar as shown on Figure 9.

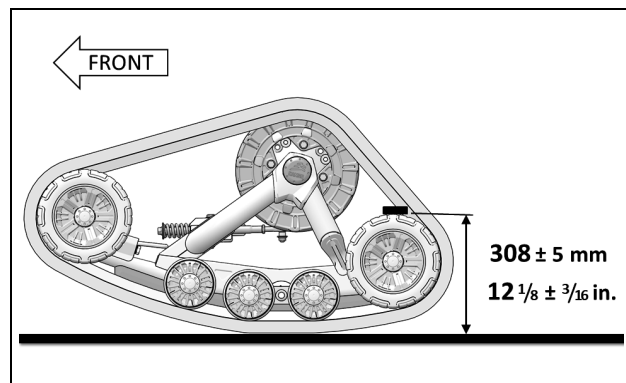

Figure 9

BASIC TUNING (Front Track Systems)

- An adjustment of more than **308 mm [12 1/8 in]**, measured with the flat bar, provides easier steering but produces a wobbling effect at high speed.
- An adjustment of less than **308 mm [12 1/8 in]**, measured with the flat bar, results in harder steering and more stability at high speed.

CAUTION: The 308 mm dimension corresponds to the required angle of attack setting. If the centered bubble in the level does not produce the required measurement of 308 mm, re-adjust angle of attack to obtain the required dimension without referring to the bubble level.

NOTE: Once angle of attack on front systems is set, verify once again to confirm adjustment.

ADJUSTMENTS

ANGLE OF ATTACK - REAR TRACK SYSTEMS

To obtain the correct angle of attack on rear Track Systems, perform the following:

RIGID AXLE OR TRAILING ARM SUSPENSION

CAUTION: Some vehicles require a particular adjustment. Refer to the *Installation Guidelines* specific to your vehicle model to confirm the adjustment.

- Stabilizing arm (1) must be attached to Track System and to rear anchor bracket (2) installed on vehicle. See Figure 10.

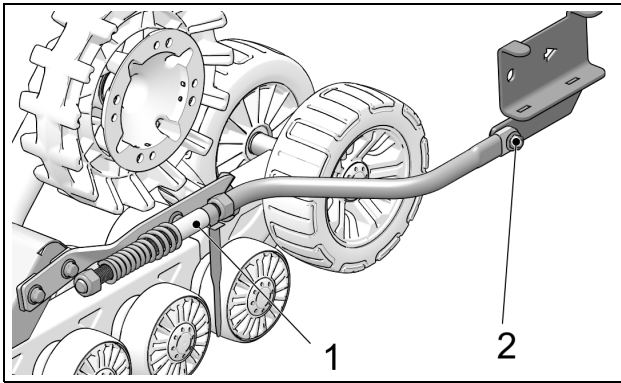

Figure 10

NOTE: Actual Rear Anchor bracket (2) installed on vehicle may differ from the one in the illustration.

- Loosen nut (3) compressing stabilizing rod spring. See Figure 11.

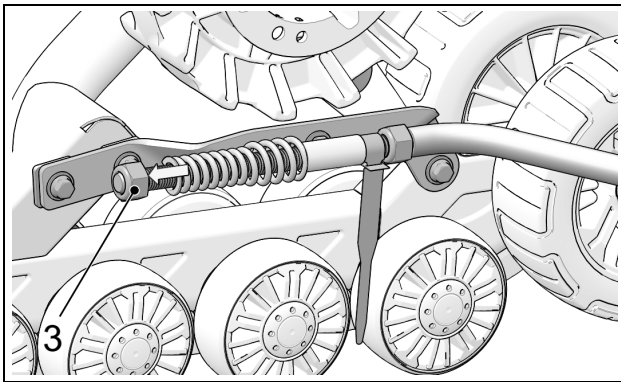

Figure 11

NOTE: Use wide part of adjusting template provided with stabilizing arm to make adjustment.

- Set nut (4) to obtain a distance of 19 mm between nut and stabilizing arm guide as shown on Figure 12.

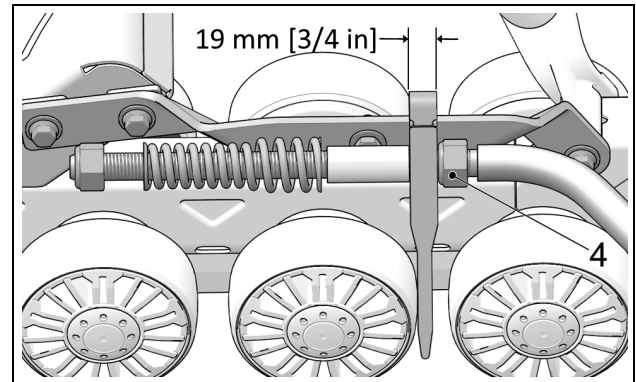

Figure 12

- Turn nut (3) until it comes in contact with spring, then compress spring by turning nut 1 1/2 turns. See Figure 13.

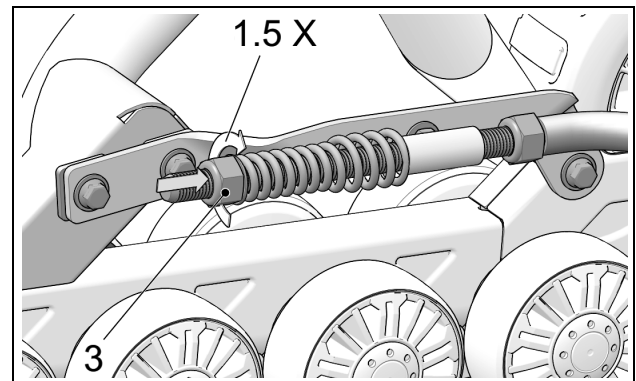

Figure 13

- **IMPORTANT:** Double-check 19 mm minimum distance between nut and stabilizing arm guide. Re-adjust as needed. See Figure 14.

NOTE: Use provided template to double-check adjustment.

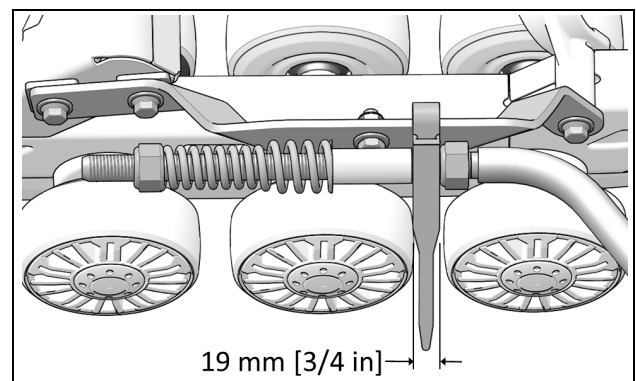

Figure 14

INDEPENDENT SUSPENSION (IS)

- Stabilizing arm (1) must be attached to rear anchor bracket (2) installed on vehicle. See Figure 15.

NOTE: Actual Rear Anchor bracket (2) installed on vehicle may differ from the one in the illustration.

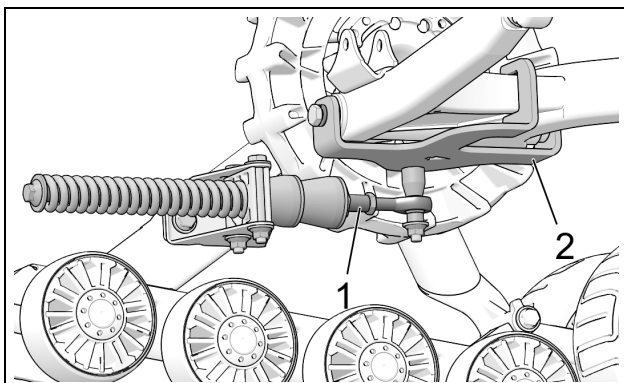

Figure 15

- Loosen anti-rotation bracket bolts (1) and (2) to allow anti-rotation retainer (3) to rotate on its axis. See Figure 16.

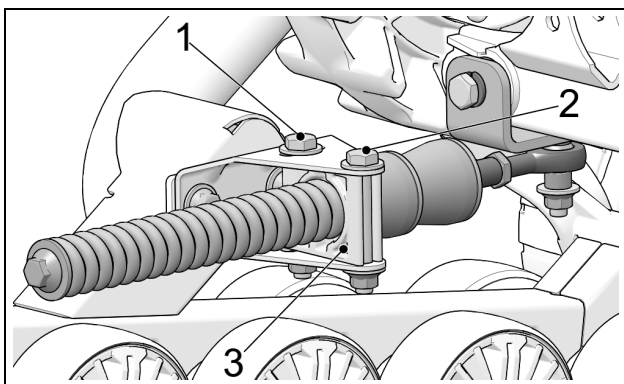

Figure 16

- Turn stabilizing arm nut to adjust length of rod end (1) and get rubber cone (2) to apply light pressure on anti-rotation retainer (3). See Figure 17.

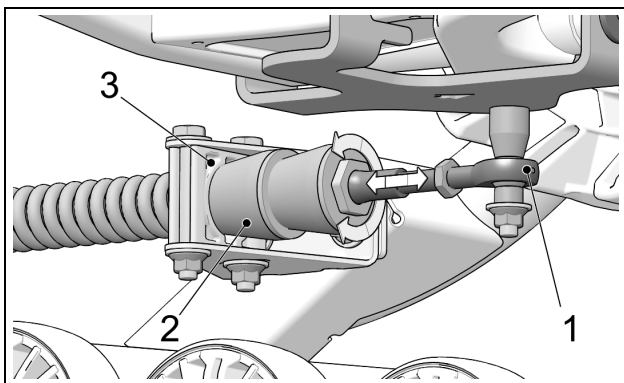

Figure 17

BASIC TUNING (Rear Track Systems):

- The adjustment is **incorrect** when the stabilizing arm's rubber cone is compressed and deformed. The stabilizing arm's spring is then difficult or impossible to turn by hand.

- Re-tighten jam nut (1) to 40 N•m [30 lb-ft] of torque when adjustment is complete. Figure 18.

CAUTION: Tighten jam nut to recommended torque specification. Overtightening nut might damage rod end.

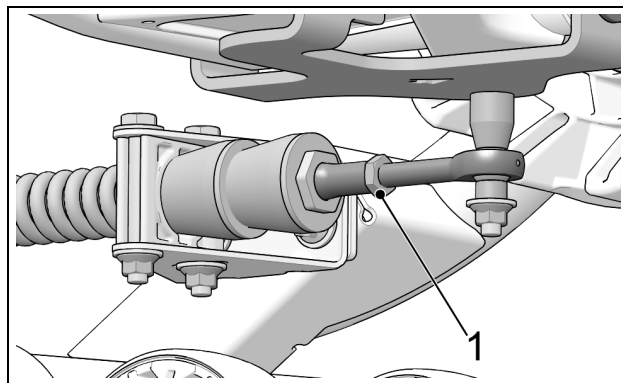

Figure 18

- Re-tighten anti-rotation bracket nuts (1) and (2) to 50 N•m [37 lb-ft] of torque. See Figure 19.

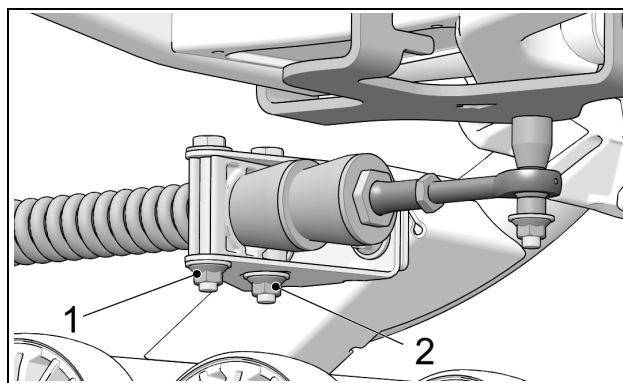

Figure 19

NOTE: Once angle of attack on rear systems is set, verify once again to confirm adjustment.

TRACK SYSTEM REMOVAL

CAUTION: Leaving the anti-rotation anchor brackets attached to the suspension arms, after having removed the Track Systems, could cause interference which might damage the vehicle. Remove all Track System anti-rotation mechanism components installed on the vehicle before reinstalling the wheels.

CAUTION: Track Systems mounted on a SxS increase ground clearance and vehicle stability. Be careful after re-installing your wheels; the handling characteristics of the vehicle will differ from those produced by Track Systems.

ALIGNMENT

Parallelism must be adjusted with the SxS on the ground, driving the vehicle forward about 3 meters [10 ft.] and measuring toe-in distance. Refer to Figure 20.

NOTE: Every time the measurement has to be taken, drive in reverse, then, drive forward again on about 3 meters [10 ft.].

CAUTION: Verify condition of the steering system components before adjusting parallelism. Damaged components can prevent proper adjustment and impair proper operation of the system.

CAUTION: The parallelism adjustment of the front Track Systems is very important and is directly linked to the longevity of the system components. Users must follow attentively the adjustment and verification recommendations of this manual.

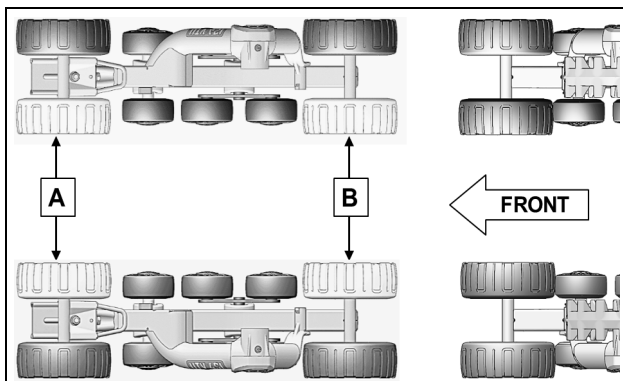

Figure 20

Dimension A: distance between inner front tires.

Dimension B: distance between inner back tires.

Dimension A must be equal to or greater than **dimension B** without exceeding **3 mm [1/8 inch]**.

A - B = 0 to 3 mm [1/8 inch]

Adjustment Method

To adjust the SxS's steering system, first loosen coupling rod nut (1), then screw or unscrew the coupling rod (2) an equal number of revolutions on both sides of the vehicle. See Figure 21.

NOTE: Starting with an open alignment setting provides a higher degree of precision in the adjustment.

CAUTION: Remember that some nuts have reverse threads before loosening a coupling rod nut (1) on the vehicle's steering system. Make sure to unlock the nut in the proper rotational direction.

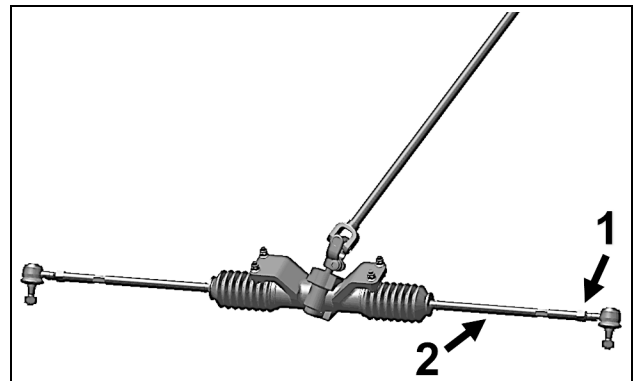

Figure 21

NOTE: Once parallelism on front systems is set, verify once again to confirm adjustment.

Measure A: Measure the distance between the front inside Ø241 mm tires of the front Track Systems. See Figures 22, 23 and 24.

Measure B: Measure the distance between the rear inside Ø241 mm tires of the front Track Systems. See Figures 25, 26 and 27.



Figure 22

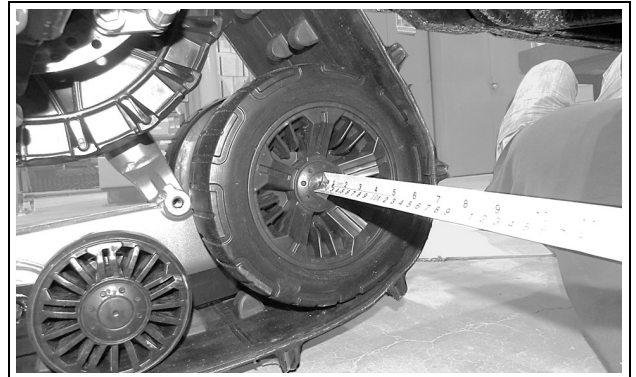

Figure 25

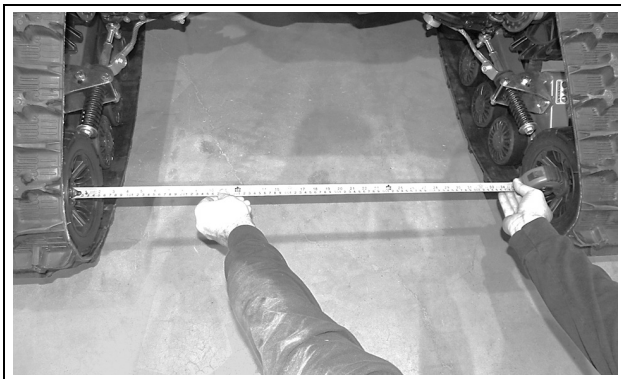

Figure 23 (Distance between front tires)



Figure 26 (Distance between rear tires)



Figure 24



Figure 27

ADJUSTMENTS

RUBBER TRACK TENSION

CAUTION: The Track Tensioner assembly bolt must be loosened to adjust track tension.

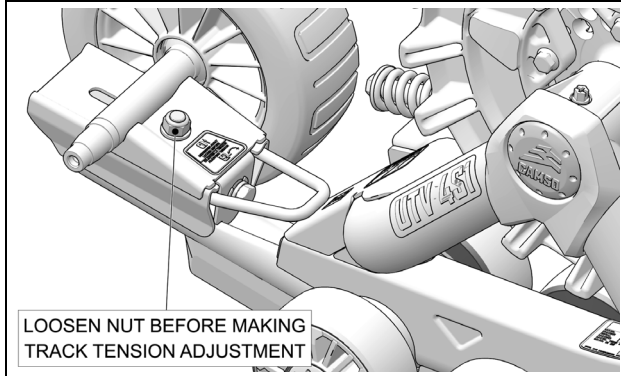

Figure 28

To adjust track tension, turn tension adjustment bolt clockwise or counterclockwise to obtain the recommended track tension. See Figure 29.

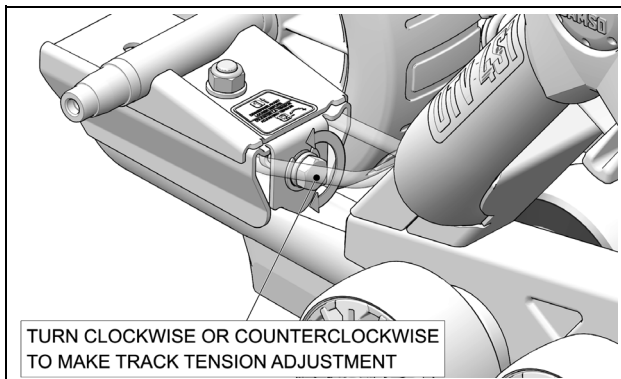

Figure 29

CAUTION: Make sure to re-tighten Track Tensioner assembly bolt after completing track tension adjustment.

The table below shows the force (1) applied and the deflection (2) which must occur to correctly set track tension. Refer also to Figure 31.

| TRACK | FORCE | DEFLECTION |
|-------|-----------------|---------------|
| Front | 13,5 kg (30 lb) | 19 mm (¾ in.) |
| Rear | 11 kg (24 lb) | 19 mm (¾ in.) |

BASIC TUNING

- A higher rubber track tension reduces the risk of “derailing” and reduces drive “ratcheting”.

NOTE: Track tension set too high could cause premature wear on system components and is therefore not recommended.

- A lower rubber track tension provides better traction, a smoother ride and better fuel economy.

NOTE: The track tension testing tool shown below in Figure 30 can be purchased through an authorized Camso dealer. The part number is 2000-00-3125.



Figure 30

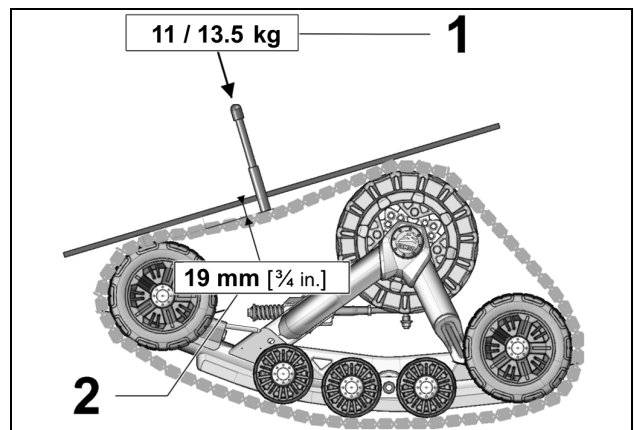

Figure 31

Final Check

Ride at slow speed on a distance of about 1.5 km [1 mile]. Re-adjust as required.

TRACKS - INSTALLATION DIRECTION

Front track: Inner driving lugs (A) are not centered on the track. Make sure the narrow side (B) is installed inside the Track system. Figure 32.

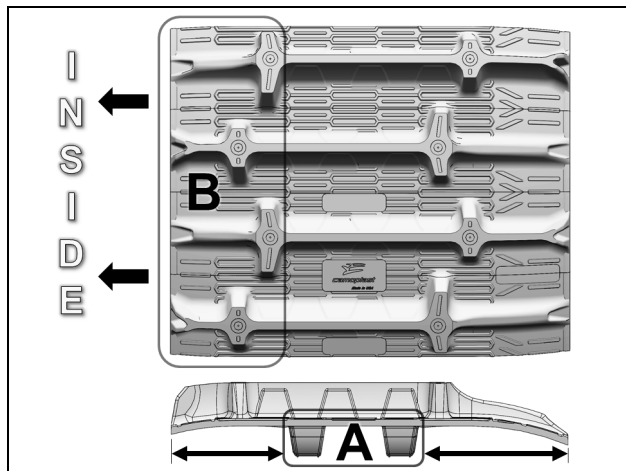

Figure 32

Rear track: Curved ends of track treads must point toward front of vehicle. See Figure 33.

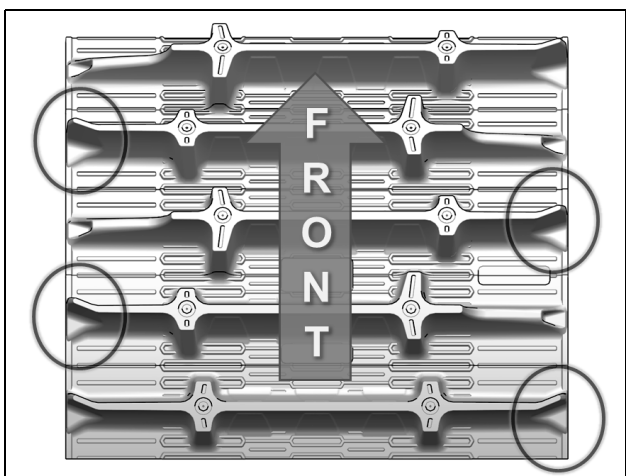

Figure 33

STORAGE

CAUTION: Contaminants can alter and corrode the moving parts of the Track System during storage. It is strongly recommended to perform the prescribed maintenance before storing the Track System.

Before storing the Track System, it is important to perform the recommended annual maintenance tasks. Refer to the maintenance chart of page 19, section *Intervals* - column *200 Hrs / Annual*.

To avoid deterioration of mechanical components due to potential prolonged exposition to water, sand, salt or other similar contaminant, it is necessary to perform the recommended tasks contained in the maintenance schedule.

The following service steps must be performed before storage:

- Clean Track system.
- Inspect Track system completely.
- Release track tension.
- Remove, clean and lubricate wheel seals.
- Lubricate hub seal.
- Verify and/or replace oil in hub.
- Verify torque on bolts.

For more details, refer to the *Maintenance*, *Lubrication*, and *Wear* sections of this manual.

Store the System by laying down each frame on its side, away from direct sunlight. Figure 34.

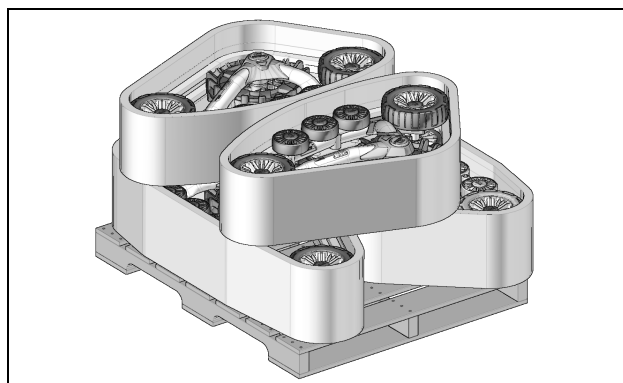

Figure 34

MAINTENANCE

WARNING

Do not insert hands or feet into or near the System unless the engine is off, and the vehicle is stopped with the security brake engaged.

CAUTION: Regular inspection, adjustment and lubrication of the Track Systems is essential to their good running order and safe operation. Users have the responsibility to perform maintenance and regularly adjust their Track Systems. The “Maintenance” section provides the necessary information to perform adequate maintenance on the Track Systems.









CAUTION: Failure to do regular maintenance at the prescribed intervals and perform the preventive adjustments indicated in the maintenance schedule can result in premature wear and important breakage on the Track Systems that will not be covered under the warranty. The user is responsible to follow the maintenance schedule provided by the manufacturer.

CAUTION: Camso recommends not using a brake cleaning solvent to clean the track system. This may damage sealing components and stickers.

The maintenance schedule has been established in order to provide optimum durability for your Track Systems. The type of usage and the conditions in which the Track Systems are used, have a direct bearing on the frequency of maintenance actions to perform. After inspection of your Track Systems, you will be able to determine if the recommended maintenance intervals are correct or to adjust them as needed.

For optimum performance and maximum durability, please refer to the maintenance chart below.

For more details on the maintenance program, consult the Maintenance specifications on page 20 and page 21.

| MAINTENANCE | INITIAL | INTERVALS | | |
|---|------------------|---|---|---|
| | FIRST USE | EVERY 25 ^A - 40 ^B HRS | EVERY 50 ^A - 75 ^B HRS | EVERY 200 HRS ^A / ANNUAL ^B |
| SYSTEM - VISUAL INSPECTION | CLEAN / INSPECT | CLEAN / INSPECT | CLEAN / INSPECT | CLEAN / INSPECT |
| SYSTEM - ADJUSTMENTS | ADJUST | INSPECT / ADJUST | | INSPECT / ADJUST |
| SYSTEM - VEHICLE ALIGNMENT | ADJUST | | INSPECT / ADJUST | INSPECT / ADJUST |
| SYSTEM - BOLT TORQUE | | | | INSPECT / ADJUST |
| TRACK - TENSION | ADJUST | INSPECT / ADJUST | | INSPECT / ADJUST |
| TRACK - WEAR | | | | INSPECT |
| WHEELS - SIDE WEAR | | | | INSPECT / REPLACE |
| WHEELS - BEARINGS | | | INSPECT / LUBRICATE | INSPECT / REPLACE |
| WHEELS - SEAL LUBRICATION  | | | INSPECT / LUBRICATE  | INSPECT / LUBRICATE  |
| FRAME - HUB BEARINGS  | | | | INSPECT / REPLACE  |
| FRAME - HUB BEARING SEAL  | | | LUBRICATE  | INSPECT / LUBRICATE  |
| FRAME - TRACK GUIDE WEAR | | | | INSPECT / REPLACE |
| FRAME - STABILIZERS | | | INSPECT | INSPECT / REPLACE |
| FRAME - CRACKS | | | | CLEAN / INSPECT |
| SPROCKET - WEAR | | | | CLEAN / INSPECT |
| ANTIROTATION - LUBRICATION | | | CLEAN / LUBRICATE | CLEAN / LUBRICATE |
| ANTIROTATION - BOLT TORQUE | INSPECT / ADJUST | | INSPECT / ADJUST | |
| ANTIROTATION - CRACKS, DEFORMATION | | | | INSPECT |
| VEHICLE - A-ARM BOLT TORQUE | | INSPECT / ADJUST | | INSPECT / ADJUST |
| VEHICLE - STEERING COLUMN | | INSPECT / ADJUST | | INSPECT / ADJUST |

A: Commercial use / Industrial use / All-season use / Wet, abrasive conditions

B: Normal winter conditions

 Important maintenance

CAUTION: Some of the repair or maintenance tasks require the use of petroleum-based products, such as oils or greases, that should not be handled directly with unprotected hands. Use protective gloves that are resistant to petroleum-based products. In case of contact with skin, clean immediately with soap and water.

MAINTENANCE - TASKS

- **Inspect:** Component(s) must be examined with care. If an anomaly is noticed, the malfunctioning component(s) must be repaired or replaced.
- **Clean:** Component(s) must be cleaned of any dirt, dust or contaminant liable to impair the proper operation of the Track System.
- **Adjust:** Component(s) must be adjusted or re-adjusted according to the manufacturer's adjustment recommendations. Refer to the relevant section of the *User Manual*.
- **Lubricate:** Component(s) need to be lubricated according to the manufacturer's recommendations. Refer to the relevant section of the *User Manual*.
- **Replace:** Component(s) must be replaced to avoid serious breakage.

MAINTENANCE - SPECIFICATIONS

System

- **Visual Inspection:** Visually inspect each Track System to detect any defect or anomaly that can impair proper functioning of the systems.
- **Adjustment:** Perform or verify angle of attack adjustments on the systems according to the manufacturer's recommendations. Refer to the *Adjustments* section on page 11.
- **Vehicle Alignment:** Perform or verify the vehicle alignment with the Track Systems installed. Follow the manufacturer's recommendations. Refer to the *Alignment* section on page 15.
- **Bolt Torque:** Check the torque of critical bolts identified in the exploded views of the system. Refer to the central pages of the *User Manual*.

CAUTION: Comply with the tightening torque recommendations and use a thread locker product if you come across a bolt that is not tightened to the manufacturer's recommendations.

Track

- **Tension:** Perform or check track tension on the systems according to the manufacturer's recommendations. Refer to "Rubber Track Tension" in the *Adjustments* section on page 17.
- **Wear:** Check wear and overall condition of the tracks on the Systems. Refer to "Wear" in the *Maintenance* section on page 26.

CAUTION: A damaged track can result in premature wear of Track System components.

Wheels

- **Side Wear:** Check side wear on Track System wheels. Replace wheel(s) if wear is too great. Refer to "Wear" in the *Maintenance* section on page 26.
- **Bearings:** Check wheel bearings for restriction, noise or abnormal play in rotation. Replace bearing if it shows one of these defects.
- **Wheel Seal Lubrication:** Wheel seals must be cleaned of any dirt or contaminant and lubricated according to the manufacturer's recommendations. Refer to "Lubrication" in the *Maintenance* section on page 23. **If a seal shows damage or any defect, it must be replaced.**

NOTE: Installing new seals when doing wheel maintenance is recommended.

NOTE: Lubrication done at the recommended intervals allows the wheel seals to maintain optimal sealing action and prolongs the useful life span of the wheels.

Frame

- **Hub Bearings:** Check hub bearings for restriction, noise or abnormal play in rotation. Bearings must absolutely be replaced if they present a defect.

CAUTION: If a hub bearing shows a defect, replace all 3 hub bearings and replace hub bearings on all 4 Track Systems at the same time.

MAINTENANCE

- **Hub Bearing seal:** The maintenance chart recommends cleaning and lubricating the hub seal. Refer to “Lubrication” in the *Maintenance* section on page 24.

NOTE: Lubrication done at the recommended intervals allows the hub seal to maintain optimal sealing action and prolongs the life span of the hub bearings.

- **Track Guide wear:** Check wear on Track Guides. Replace guides if wear is too great. Refer to “Wear” in the *Maintenance* section on page 26.
- **Stabilizers and Wheel Shafts:** Check condition of vulcanized rubber envelopes around Stabilizers and Wheel Shafts embedded in the frame. Stabilizers and Wheel Shafts must be perfectly centered in the frame. Lateral play may indicate that the envelope no longer strongly adheres to the Stabilizer or Wheel Shaft. Replace problem component if it is not well supported in the vulcanized rubber envelope. Refer to “Wear” in the *Maintenance* section on page 27.
- **Cracks:** Visually inspect the frames for presence of cracks or defects that can impair proper operation of the Track Systems. Replace components if damaged.

Sprockets

- **Wear:** Check wear of sprockets on the Systems. Replace if wear is too great. Refer to “Wear” in the *Maintenance* section on page 27.

Anti-rotation

- **Lubrication:** The maintenance chart recommends cleaning and lubricating the anti-rotation arms. Refer to “Lubrication” in the *Maintenance* section on page 25.
- **Bolt Torque:** Verify torque of assembly bolts on anchor brackets and anti-rotation arms at the recommended intervals specified by the maintenance chart.
- **Cracked or bent parts:** Visually inspect anti-rotation arms for presence of cracked or bent parts that can impair proper functioning. Replace components if damaged.

- **Rubber Dampers:** Verify condition of rubber dampers on anti-rotation arms. Replace dampers if they are deformed, cracked or show severe wear. Refer to “Wear” in the *Maintenance* section on page 27.

CAUTION: When pressure washing the Track Systems, care must be taken to keep the water stream away from wheel and hub bearing seals and from rubber caps.

CAUTION: Use a breaker bar to remove the hub assembly bolt. Do not use an air impact wrench. It might cause the bolt to break.

CAUTION: Always replace washer and hub assembly bolt when removing the hub from the frame. Use new fasteners at reassembly.

NOTE: Pour 8 to 12 cc of 80w90 oil through hole on top of hub housing intended for this purpose. Refer to “Lubrication” in the Maintenance section on page 24.

SPECIAL TOOLING

Wheel Extractor

Camsco Part Number: 2000-00-1050

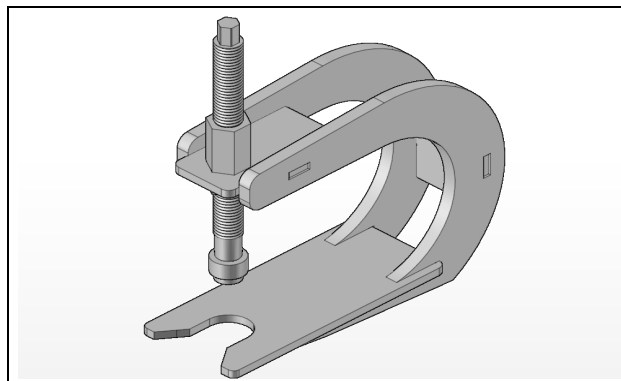
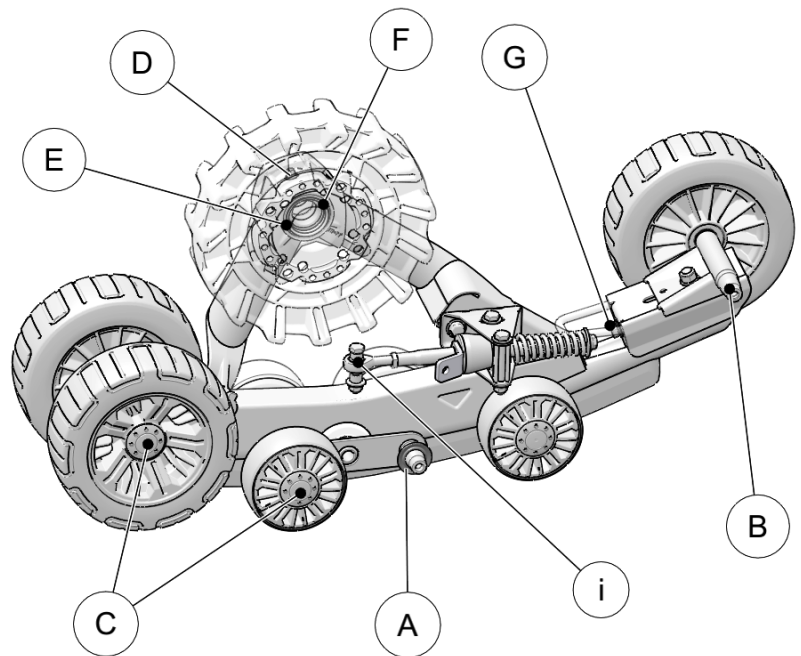

Figure 35

NOTE: The Wheel Extractor cannot be used to extract Stabilizer wheels.

LUBRICATION



- A WHEEL SEALS
- B WHEEL SHAFTS
- C WHEELS
- D HUB HOUSING
- E HUB SEALS
- F HUB - SPEED SLEEVE
- G TRACK TENSIONER
- H ANTI-ROTATION ARMS
- i ROD ENDS

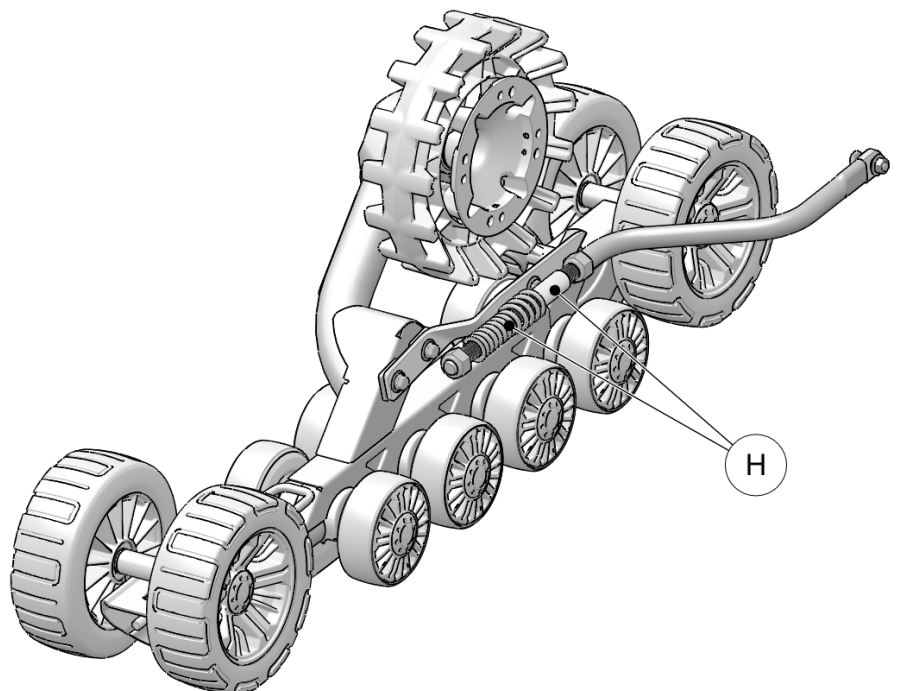

LUBRICATION

The maintenance chart on page 19 includes lubrication maintenance that must be performed on Track Systems. Refer to the following recommendations for optimal lubrication.

NOTE: Use a grease designed for operation in cold temperature and in extreme and wet environments.

REFERENCE "A"

WHEEL SEAL LUBRICATION

Install new seal on clean, dry wheel shaft at position shown below.

NOTE: Installing new wheel seals is recommended when lubricating these components.

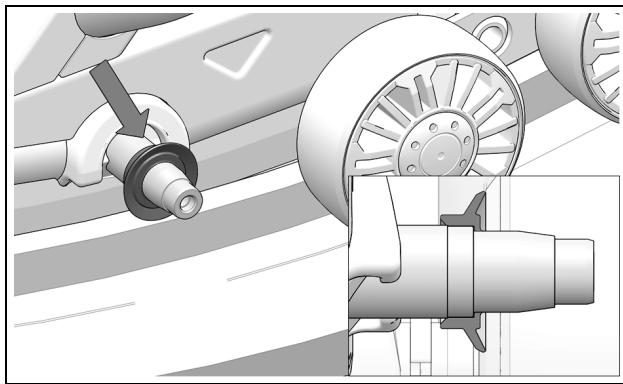

Apply evenly 3 to 3.5 cc of grease all around the wheel seal's V-shaped groove.

NOTE: V-shaped groove must be filled with grease all around.

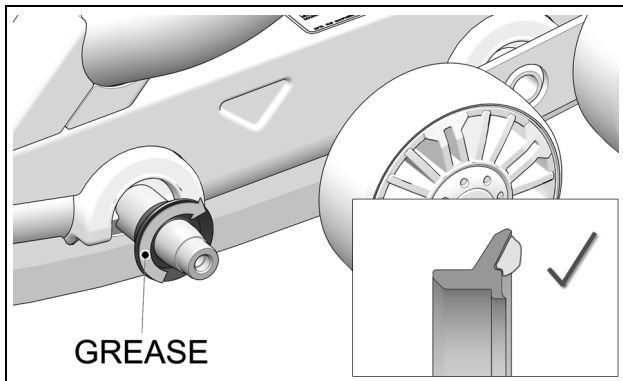

REFERENCE "B"

WHEEL SHAFT LUBRICATION

Apply evenly 1 to 1.5 cc of grease on the wheel shaft, over the entire circumference (360°) and width.

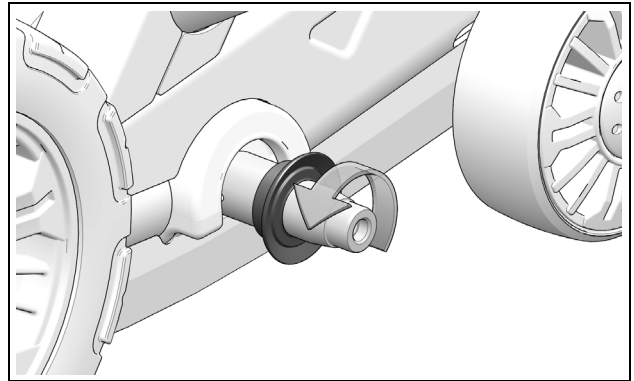

REFERENCE "C"

WHEEL BEARING LUBRICATION

Unbolt wheel from frame and carefully remove exterior bearing seal (1) of both bearings. Clean off old lubricant and pack with new grease. Lastly, re-install seals over matching bearings.

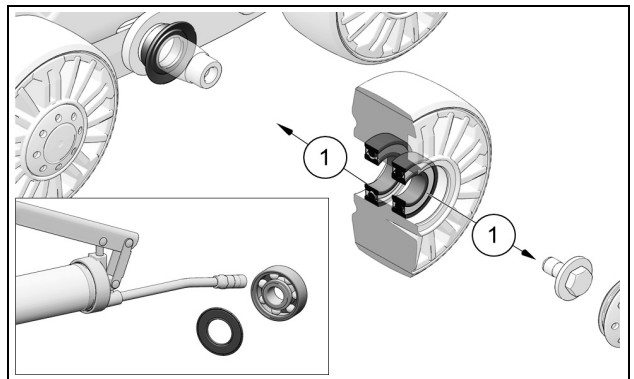

CAUTION: Take special care to avoid damaging the bearing seals when you remove and reinstall them.

WHEEL LUBRICATION

Camsco recommends pouring 5 cc of oil under the wheel caps and between the wheel bearings, at every maintenance interval. This will help minimize the presence of contaminants and extend wheel bearing life.

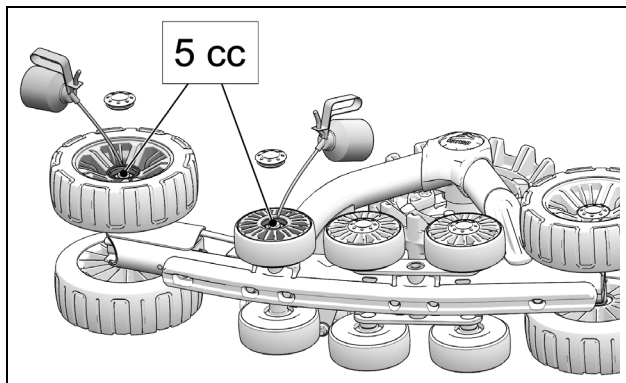

REFERENCE "D"

HUB LUBRICATION

Following replacement of hub bearings and/or re-installation of hub, pour 8 to 12 cc of oil through hole on top of hub housing intended for this purpose.

NOTE: Use a SAE 80W-90 grade oil designed for high pressure applications.

CAUTION: Do not exceed the recommended quantity of oil.

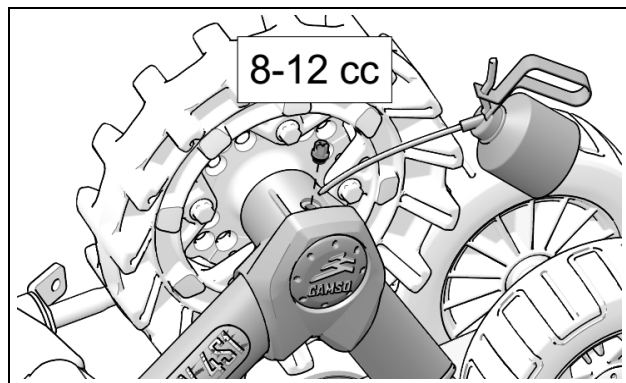

REFERENCE "E"

HUB BEARING SEAL LUBRICATION

Apply evenly 1.5 to 2 cc of grease between the hub seal lips and on its the entire circumference (360°).

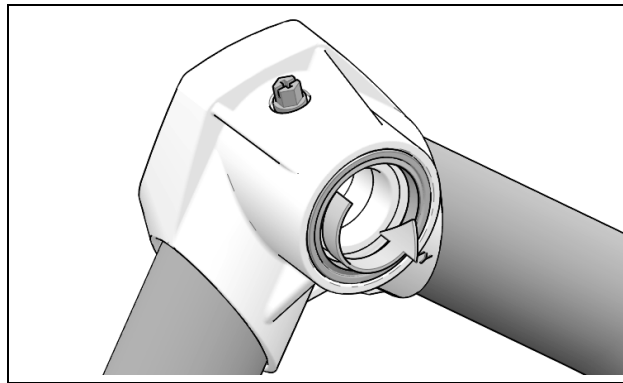

IMPORTANT: The hub seal must be installed flush with the hub face.

CAUTION: Replace hub seal immediately if defective.

REFERENCE "F"

LUBRICATION OF HUB SPEED SLEEVE

Apply 1.5 to 2 cc of grease over the entire width and circumference (360°) of the hub Speed Sleeve.

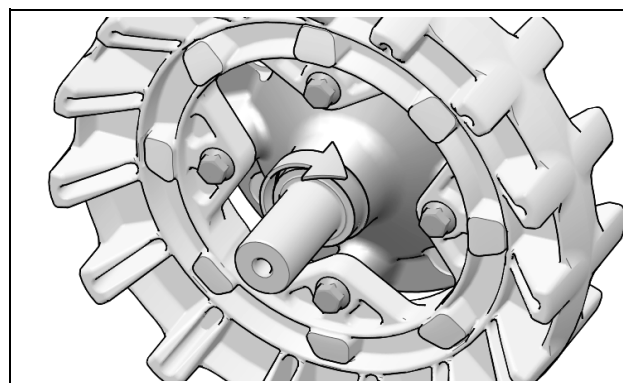

CAUTION: Replace Speed Sleeve (P/N 1093-00-7003) immediately if it shows wear.

REFERENCE "G"

TRACK TENSIONER

Loosen Track Tensioner assembly bolt (1). Apply aerosol grease through openings on each side of Track Tension adjustment bolt (2).

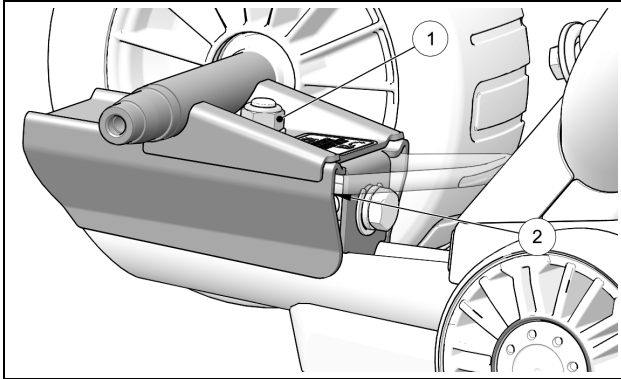

NOTE: Following application of grease, rotate adjustment bolt to move Track Tensioner to its maximum and minimum positions. Re-adjust Track tension afterwards. For more details, refer to "Rubber Track Tension" section on page 17.

REFERENCE "H"

STABILIZING ARM LUBRICATION

Clean and apply spray lubricant all around Rear Stabilizing arm compression spring on vehicles equipped with a rigid rear axle suspension.

REAR SYSTEMS - RIGID AXLE SUSPENSION

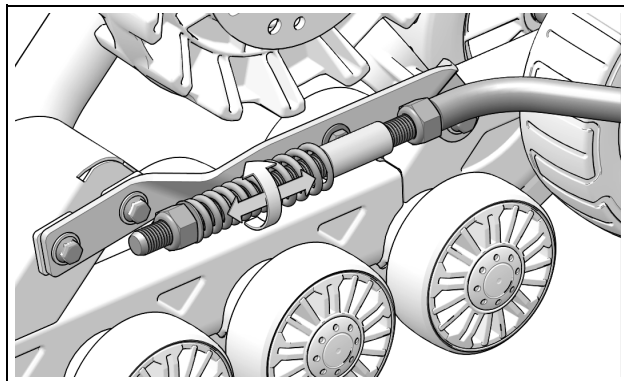

LUBRICATION OF STABILIZING ARM GUIDES - RIGID SUSPENSION

Apply spray lubricant to the Stabilizing Arm guide and threaded shaft, on Track Systems with an anti-rotation mechanism designed for vehicles with a rigid rear axle suspension.

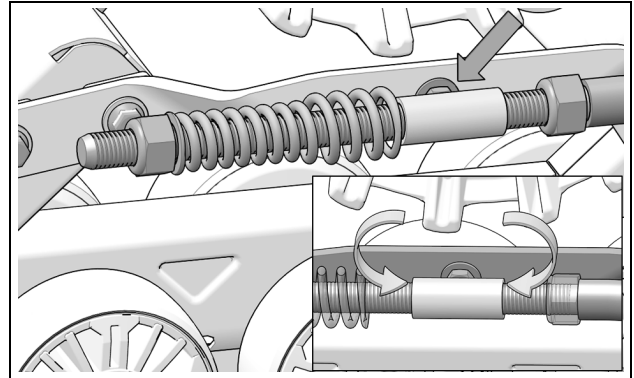

REFERENCE "i"

LUBRICATION OF STABILIZING ARM ROD ENDS

Clean and apply spray lubricant to rod ends of Stabilizing Arms.

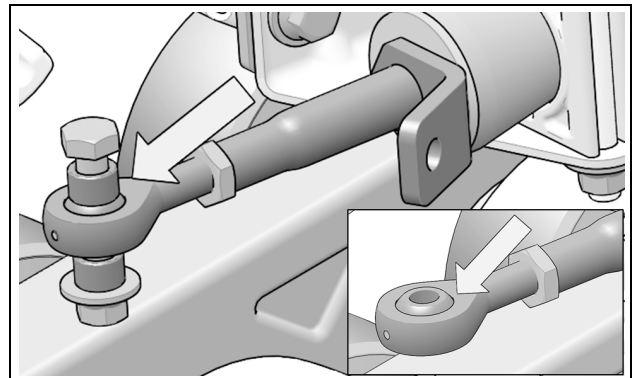

NOTE: For maximum durability of rod end, disassemble rod end assembly and rotate ball in its seat to distribute lubricant.

WEAR

Wheels

Verify wear on wheels especially on the interior guidance strip. The wheel must be replaced if the inner surface (1) is perforated or when the wheel's rolling band narrows to a width of less than 45 mm. A wheel that is excessively worn will not offer enough support to guide the track. Track guides may also wear prematurely. Figure 36.

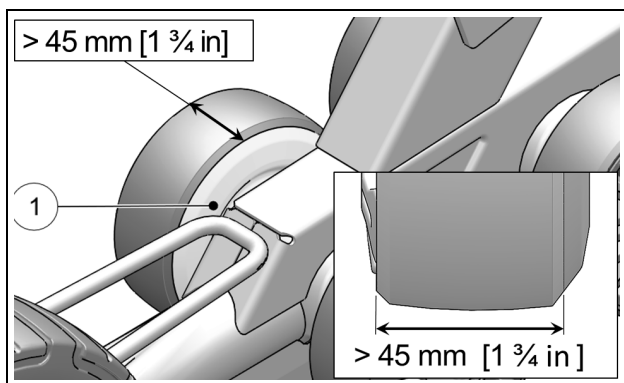

Figure 36

Urethane Tires

Verify wear on the Urethane Tires especially on the interior guidance strip (1) and between the tire profiles (2). The wheel must be replaced if the inner surface is worn out or the tire is cracked between the tire profiles. A wheel that is excessively worn will not offer enough support for track guidance. Track guides may also wear prematurely. Figure 37.

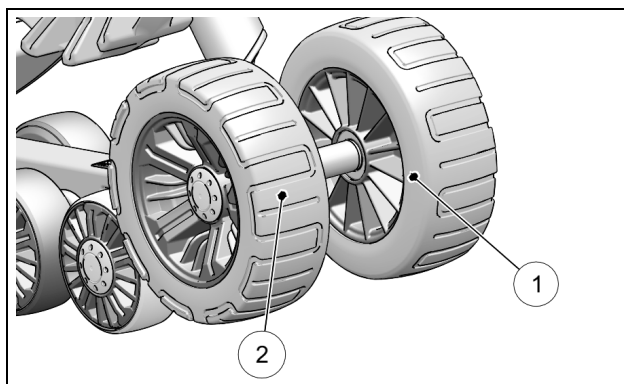

Figure 37

Track

Wear of external profile impacts track performance directly. Important wear on profiles means less traction. Replace track if you notice a significant loss of performance. Verify internal and external rolling path, profiles, and driving lugs. Presence of tears, perforations or delamination in these places can render the Track system inoperable. Replace track to prevent failure risks. See Figure 38.

CAUTION: Too much wear could cause damage to the Wheels and to the Track guide.

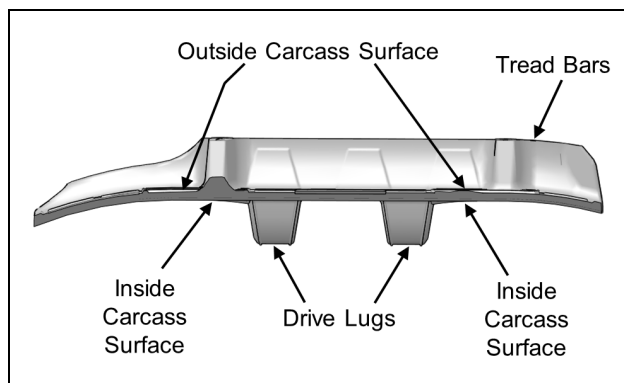

Figure 38

Track Guide

Verify wear on the Track Guide by measuring the width of guide rails. If rail dimensions, illustrated in Figure 39, are less than 5 mm, at any point along the Track Guide, replace the part. If the guide rails are worn to the point that the concave shape is no longer visible, replace the part.

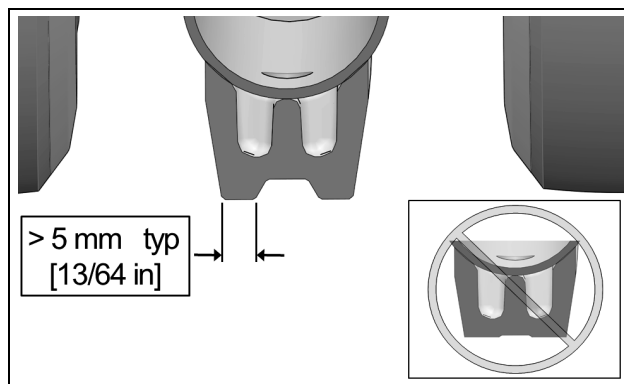

Figure 39

CAUTION: An overly worn Track Guide could cause premature wear and damage on other guidance components of the system.

Rubber Dampers (Stabilizing arms)

Check wear and damage on rubber dampers (1) mounted on the stabilizing arms. Replace them if they show cracks or are excessively worn or deformed. See Figure 40.

CAUTION: Improperly adjusted Track systems can deform and damage the Rubber Dampers as well as impair proper operation.

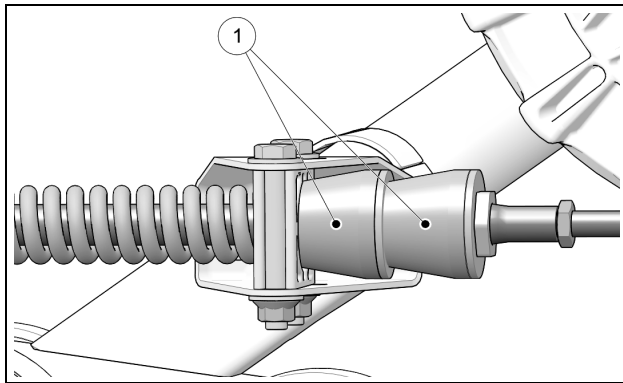

Figure 40

Sprocket

Check wear on Sprocket by measuring sprocket teeth as illustrated on Figure 41. Replace sprocket if dimensions are less than 19 mm.

CAUTION: Excessive wear could lower track drive efficiency and reduce System performance.

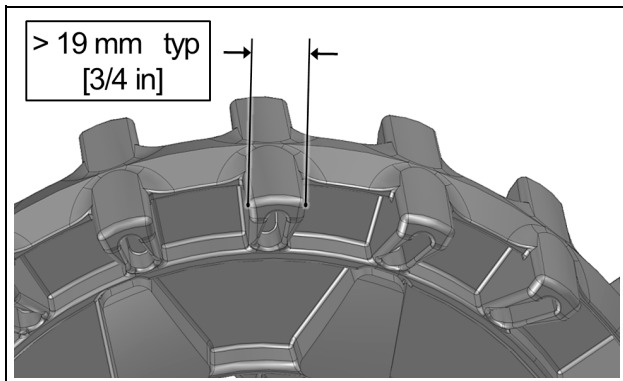

Figure 41

CAUTION: In order that wear on sprockets be produced evenly across all 4 sprockets, the vehicle should be driven in 4x4 mode, especially in abrasive conditions.

Vulcanization - Stabilizer and Wheel Shaft

Verify if vulcanized rubber supports (1) on Stabilizers (2) and Wheel Shafts (3) are well secured and are not showing signs of detachment (ungluing) between components. Figure 42.

CAUTION: Replace part if vulcanized rubber component is ungluing from metal tubing. Using the parts when the bond between the two components is broken can result in wear and important damage to the Track Systems.

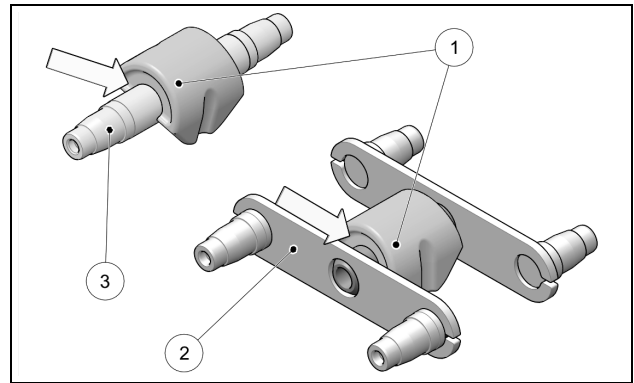

Figure 42

Anti-rotation

Verify wear on ball joint of Stabilizing Arm to make sure that it is not seized or too loose. Figure 43.

CAUTION: A damaged ball joint can impede Track System adjustments and result in damages to the Track Systems and to the Vehicle if not replaced.

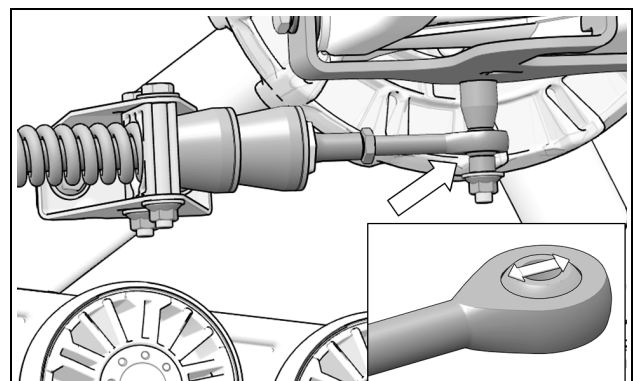

Figure 43

2-YEAR LIMITED WARRANTY

Camso guarantees that the new, unused **Camso® UTV 4S1** System (System) installed by an authorized dealer or distributor is free from any defects in materials and workmanship during the period and in conditions described below. When operating a new **Camso® UTV 4S1** System, the user agrees that the present form is applicable and exclusive, that they have been signified and that they have been accepted by him/her at the time of purchase.

The SxS **Camso® UTV 4S1** Track System is covered by a manufacturer warranty (warranty). The warranty covers manufacturing defects related with materials and workmanship. The installation and maintenance of the System is always the responsibility of the owner.

PERIOD OF COVERAGE

The warranty is valid for a period of twenty-four (24) months following the date of purchase. This warranty does not apply to normal maintenance.

The warranty applies exclusively to parts and components of the Track System. All paint defects on the System (frames and components) are not covered.

The warranty is not valid if the System is not installed by an authorized Camso network dealer or distributor.

This warranty specifically excludes any damage or breakage to the SxS and related defects on the SxS, whether or not these were caused or believed to be caused by the System.

The manufacturer is not responsible for damages, injuries or loss caused at the time of or after installing of the System on the vehicle.

For a warranty to be valid, the System owner must comply with manufacturer notices and warnings. In addition, all claims must be accompanied by a proof of purchase (original receipt or sale contract) and work or repairs must be performed by an authorized Camso dealer. All claims not previously approved and authorized by Camso will be rejected.

The following situations and items are not under any circumstances covered by the warranty:

- 1) Any and all consequential damages, including, but not limited to, indirect costs, such as towing, storage, phone calls, renting, transportation, inconveniences, insurance coverage, reimbursement of loss, loss of time and loss of revenue, etc.
- 2) Damage resulting from faulty installation.
- 3) Damage resulting from normal parts wear or progressive deterioration owing to the distance covered with a vehicle on which the System is installed.
- 4) Damage resulting in non-compliance with the user manual and with maintenance instructions recommended in the user's manual and other technical documents.

5) Damage resulting in abusive use, abnormal use, negligence or even a use which does not comply with recommendations of the manual, excess weight or loading, including excessive number of passengers.

6) Labor costs, parts and materials related any and all maintenance costs.

7) Damage resulting from faulty repairs, improper maintenance or any unauthorized changes made to the System other than those specified by the manufacturer or from the installation of non-original or unauthorized parts that were not produced or approved by Camso.

8) Damage resulting from an accident, incident, robbery, vandalism, war or unforeseen event or act of God.

9) Regardless of cause, damage resulting from inexperience, driving errors, accident or other incident.

10) The use of the System on a vehicle used for public rental, including by a previous owner, will render this warranty null and void.

11) The use of the System in races, rallies or other competitive events/activities of this type, at any time, including from a previous owner or in conditions that do not comply with those described by the manufacturer will render the warranty null and void.

Any repaired or replaced components or parts are guaranteed only to the extent of the original warranty. In other words: if a warranted part was replaced after nine (9) months, the new replacement part will only be guaranteed for fifteen (15) months, for a total of twenty-four (24) months. Any claim for a track will be established according to its residual value, 100% during the first 12 months, 75% between 12 and 18 months and 50% between 18 and 24 months. The residual value will have to be applied in the form of reduction to the purchase of a track of replacement at regular price. In no event shall the warranty extend beyond a total of twenty-four (24) months from the date of original System purchase.

In all cases, the warranty is limited to a maximum of the original purchase price or the fair market value of the System. Camso will have final authority in determining the fair market value of a used System. The warranty is applicable within the limits and conditions initially contracted. If the System is determined to be unusable due to accident or improper repair, the warranty will be considered null and void without further recourse available to the System owner.

The manufacturer, the retailer and/or the repair shop shall not be held responsible for any delays caused by material, parts or components availability or backorder.

*Shipping and handling costs, as well as any fees related with shipping or transportation of the System to the dealer location are the responsibility of the System owner.

Camso reserves its sole and exclusive right to update or modify this warranty without impact on end users. All previous terms and conditions of the warranty at time of purchase will be respected.

TROUBLESHOOTING

| PROBLEM | POTENTIAL CAUSE | CORRECTION |
|---|---|---|
| Abnormal vibration | Presence of debris in the system | Remove any debris that could prevent proper operation of the system |
| | Severe and localized wear on a wheel (flat spot) | Replace part |
| | Frozen sprocket or wheel | Remove ice/snow build-up. Storing the vehicle at temperatures higher than 0°C might be required |
| | | Surface wear on components increases adherence of ice/snow on parts. Replace the worn components |
| | Beginning of derailing | Verify if tensioner assembly nut is adequately tightened |
| | | Check wear on tires wheels, track guide and track drive lugs |
| | Presence of dirt between wheel hub and track system hub could cause incorrect seating of mating surfaces when installing track system | Remove system and clean contact surfaces between hubs |
| | Damaged Hub or wheel bearing | Replace damaged wheels or bearings |
| Wheel Hub or Track system hub deformed following an impact or abusive use | Replace deformed part | |
| Unstable behavior | Incorrect adjustment of angle of attack | Adjust angle of attack according to manufacturer's specifications. (Refer to <i>Adjustments</i> section in <i>User Manual</i>) |
| | Track tension too high | Adjust track tension. (Refer to <i>Adjustments</i> section in <i>User Manual</i>) |
| | Misalignment of Track System | Correct alignment. (Refer to <i>Adjustments</i> section in <i>User Manual</i>) |
| Overheating of System guiding components (burned rubber or plastic odor) | Blocked wheel or tire | Try to free the wheel/tire and replace it if necessary |
| | Misalignment of System | Correct Track System alignment. Refer to <i>Adjustments</i> section in <i>User Manual</i> |
| | Constant turning | Vary your turning radius and seek areas that can help lubricate the System |
| | Uninterrupted use of the System in rutted trails | Vary your line (out of ruts) and seek areas that can help lubricate the System |

| PROBLEM | POTENTIAL CAUSE | CORRECTION |
|-----------------------------|---|--|
| Loss of power | Track Tension too high | Lower track tension |
| | | Clean sprockets of all mud or snow build-up, or of any other contaminant |
| | | Remove ice/snow build-up on wheels |
| | | Clear all compacted snow between frame and wheels |
| | Snow infiltration in vehicle's air intake or clutch system | Remove snow and contact dealer immediately to fix the situation |
| Partial or total derailing | Severe wear on one or several components | Verify if tensioner assembly nut is adequately tightened |
| | | Check wear on track guide, inside driving lugs and wheels/tires |
| | Track tension too low | Adjust track tension on Track System units. Refer to <i>Adjustments</i> section in <i>User Manual</i> |
| | Misalignment of Track System and/or incorrect angle of attack | Adjust angle of attack of Track System and vehicle alignment as per manufacturer's specifications. Refer to <i>Adjustments</i> section in <i>User Manual</i> |
| Insufficient snow flotation | Incorrect adjustment of anti-rotation mechanism | Adjust angle of attack as per manufacturer's specifications. Refer to <i>Adjustments</i> section in <i>User Manual</i> |
| | | Worn or damaged rubber damper or stabilizing rod |

"CE" DECLARATION OF CONFORMITY

DECLARATION OF CONFORMITY



WE:

MANUFACTURER: Camso Inc.
ADDRESS: 4162, rue Burrill, Local A, Shawinigan (Québec), Canada G9N 0C3
WEB SITE: www.camso.co

HEREBY DECLARE THAT THE PRODUCT SERIES:

PRODUCT: UTV 4S1 Track System
CUSTOMER:

IS IN CONFORMITY WITH THE FOLLOWING STANDARDS:

| NUMBER: | TITLE: | DATE: |
|-------------------|--|-------|
| IEC/IEEE 82079-1 | Preparation of information for use of products | 2019 |
| ISO 12100 | Safety of Machinery | 2010 |
| ISO/IEC 17050-1&2 | Conformity Assessment | 2005 |

AND IN CONFORMITY WITH THE FOLLOWING EC DIRECTIVE:

| NUMBER: | TITLE: | DATE: |
|-------------|--------------------------------|-------|
| 2006/42/EEC | Safety of machinery directives | 2006 |

DONE AT:

Shawinigan (Québec), Canada

PERSON IN-CHARGE: _____

TITLE: _____

SIGNATURE: _____

DATE: _____



ENVIRONMENT

Track Systems are made of varied materials: steel, aluminum, rubber, plastic, grease & oil used by the manufacturer. Please recycle, re-use, or dispose of components at appropriate depot facilities when Track Systems come to the end of their life.

PATENTS

The Camso UTV 4S1 System is covered by the following patents:

- CA 2 405 908
- CA 2 493 181
- CA 2 822 562
- CA 2 825 509
- CA 2 552 119 *
- CA 2 770 498 *
- US 6 935 708
- US 7 229 141
- US 8 347 991
- US 8 662 214
- US 9 033 430
- US 7 708 092 *
- US 8 297 383 *

* inventor: Jean Després

TRACK SYSTEM VIEWS

Exploded views of Track Systems and Service kits are available on Camso’s website.

<https://camso.co/en/powersports/atv-utv/service-and-support>

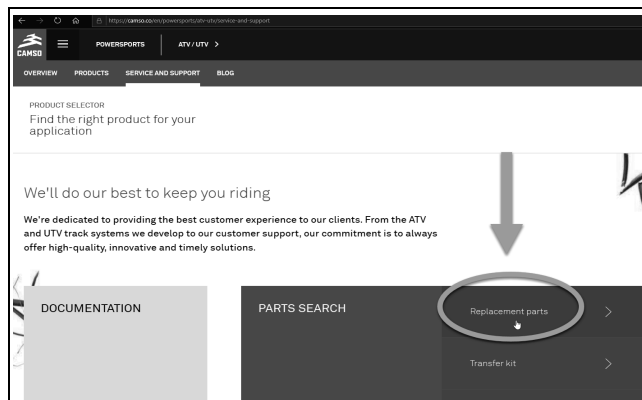
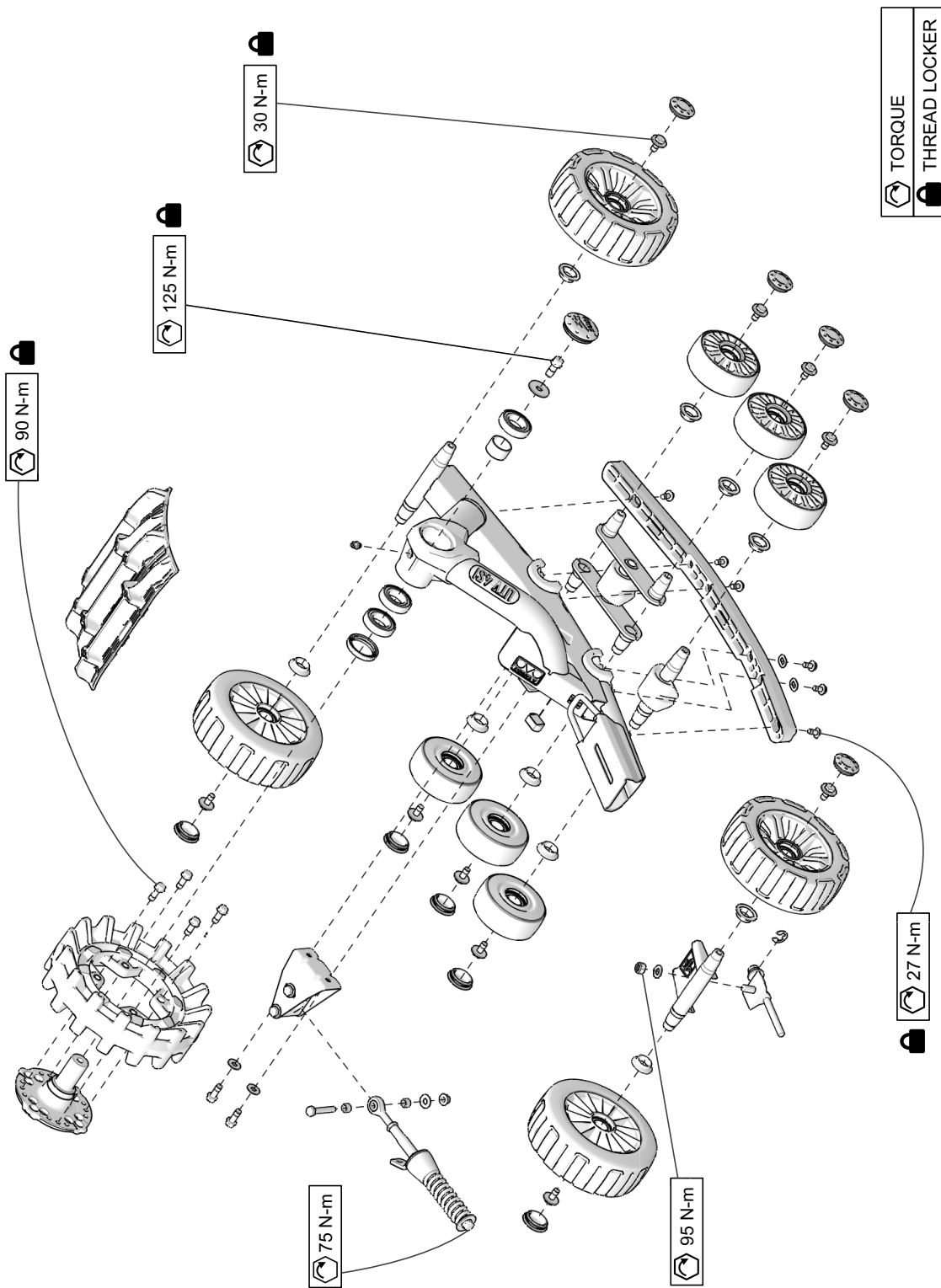

Figure 44





FRONT SYSTEMS

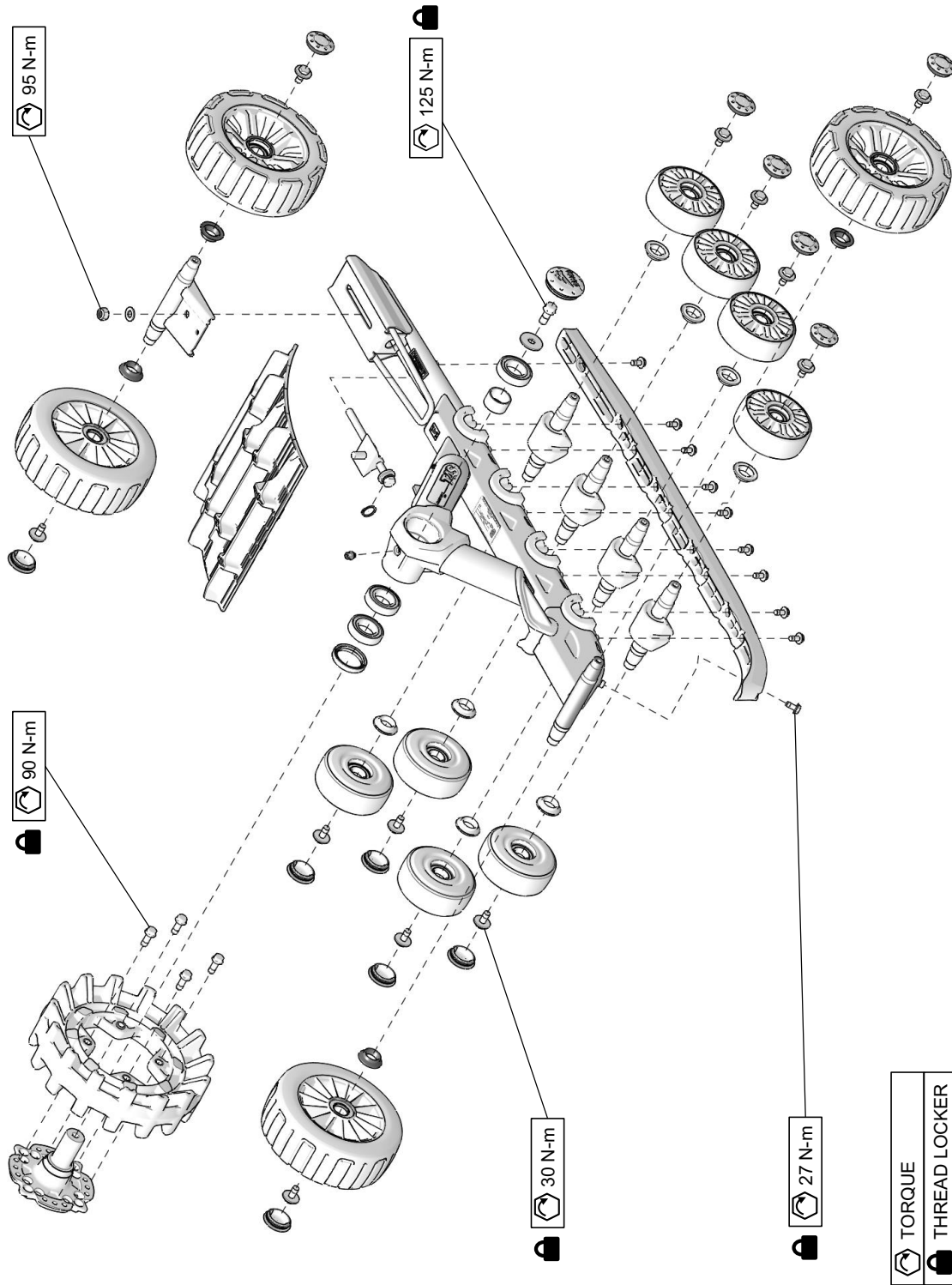

REAR SYSTEMS





TORQUE SPECIFICATIONS

| |
|---|
|  TORQUE |
|  THREAD LOCKER |

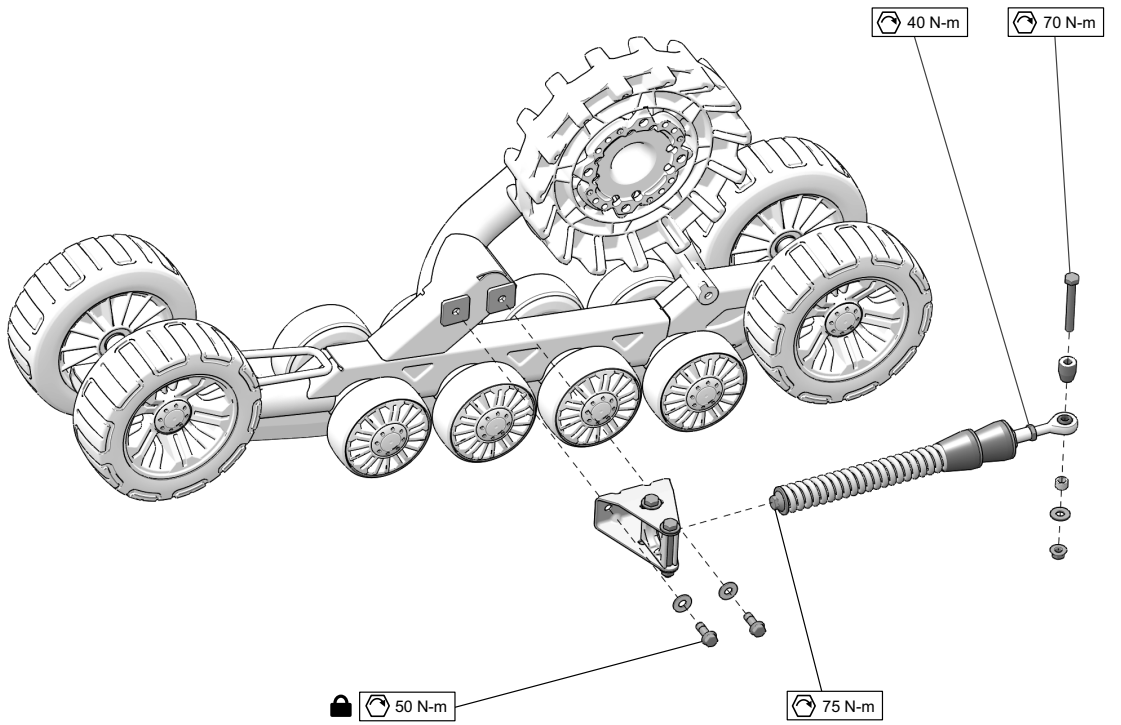
- REAR - INDEPENDENT SUSPENSION



| |
|---|
|  TORQUE |
|  THREAD LOCKER |

- REAR - RIGID SUSPENSION

