

CAMSO ATV R4S FOR ALL-TERRAIN VEHICLES ADJUSTMENTS 2020

1099-00-7731



ATV R4S



INTRODUCTION

These guidelines are designed to provide you with the information necessary to perform the required adjustments to the System. The right adjustments have a direct impact on performance and lifespan of the System's components. It is important to follow closely the instructions contained in this document in order to make the correct system adjustments and thereby reach optimum system performance.

Follow all the instructions contained in this document. To make sure that every step has been performed, a checklist is provided at the end of the instructions to verify that all the adjustments have been made.

IMPORTANT

The warranty does not apply if the Track System was installed by someone other than a Camso dealer or authorized distributor.

IMPORTANT

Verifying your adjustments on the systems is mandatory after the first use of the vehicle; the track tension, alignment and angle of attack of each track system must be re-verified. Incorrect adjustments can decrease the performance of the systems and result in premature wear or breakage of certain components.

IMPORTANT

Before starting the installation, verify that serial numbers are identical on all 4 track systems. The serial number's last digit (0, 1, 2, 3) indicates the mounting position on the vehicle. Lay out the track systems accordingly. Refer to Figure 1 and Figure 2.

NOTE: If Track System serial numbers do not match, contact your authorized Camso dealer / distributor.

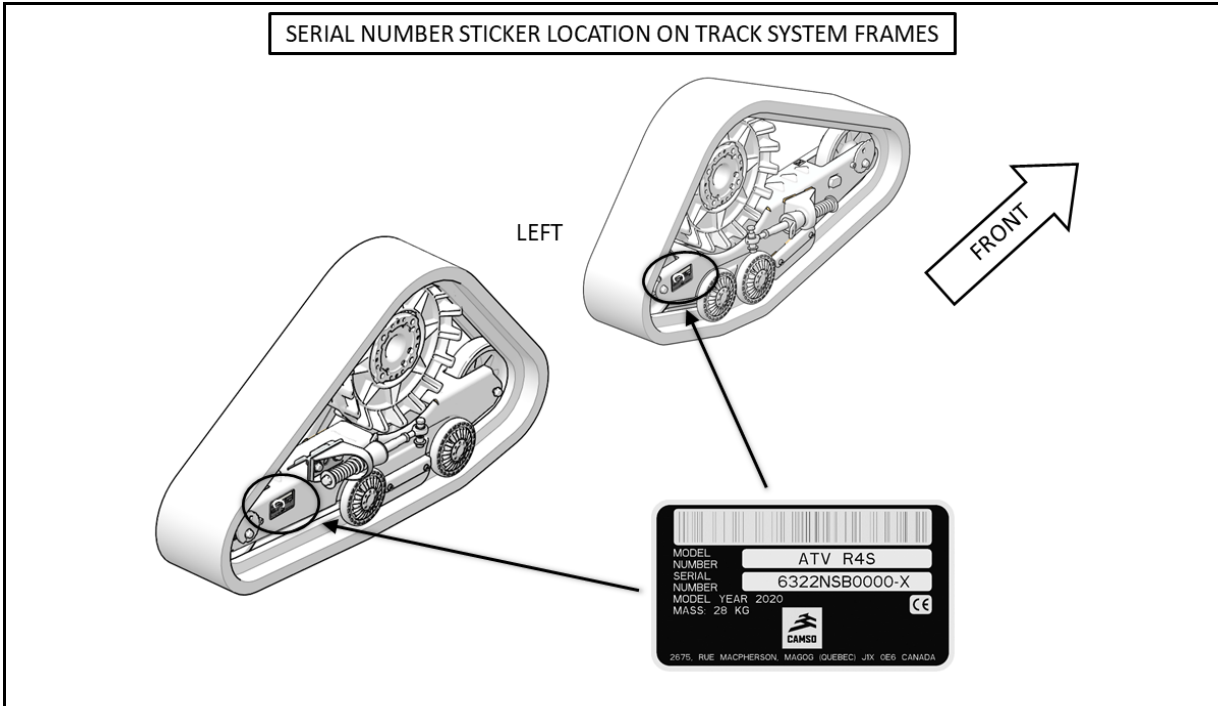

Figure 1

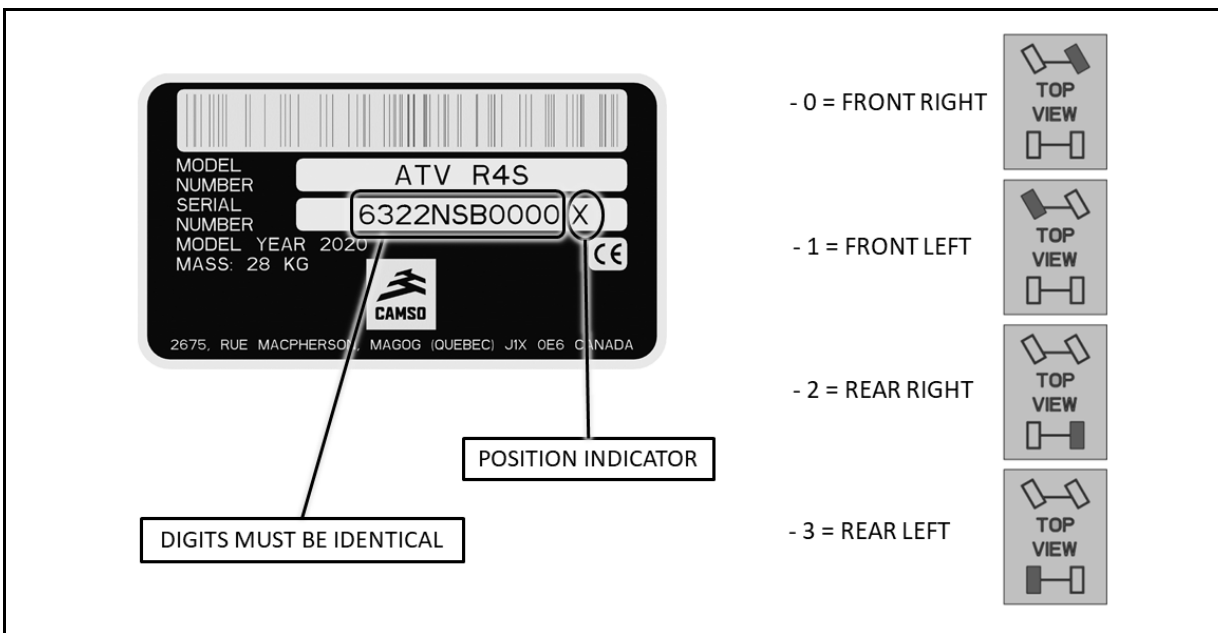

Figure 2

ADJUSTMENTS

NOTE: To make the following adjustments, position the vehicle on a flat and level surface.

ANGLE OF ATTACK - FRONT SYSTEMS

To obtain the correct angle of attack on front Track Systems, perform the following:

- Use handlebars to point tracks straight ahead.
- Temporarily apply pressure to the front of the track to make stay flat on the ground.
- Stabilizing arm (1) must be attached to front anchor bracket (2) mounted on vehicle. Figure 3.

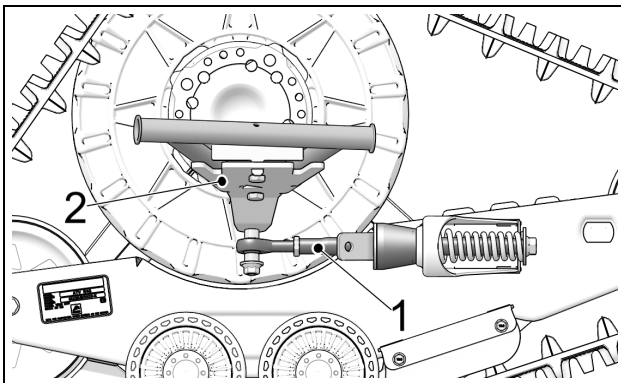

Figure 3

- A Bubble Level (1) is attached to the inside of the front frames. A perfectly centered bubble is needed to adjust the angle of attack correctly. See Figure 4.

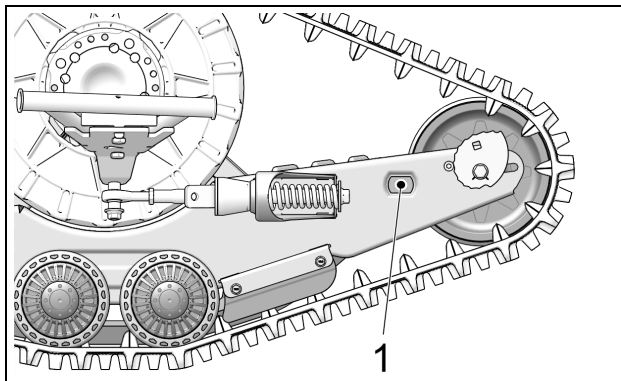

Figure 4

NOTE: Before each measurement, temporarily apply light pressure to the front of the track to make sure that it stays flat on the ground.

- Loosen jam nut (1). Adjust length of rod end (2) by rotating the steering limiter support plate on (3) the stabilizing arm. Use a 30 mm wrench to rotate support plate to obtain a perfectly centered bubble in the level. Refer to Figure 5.

NOTE: Stabilizing arms on front Track Systems incorporate a steering limiter support plate (3) that is bent. This plate should be positioned inwards, towards the vehicle.

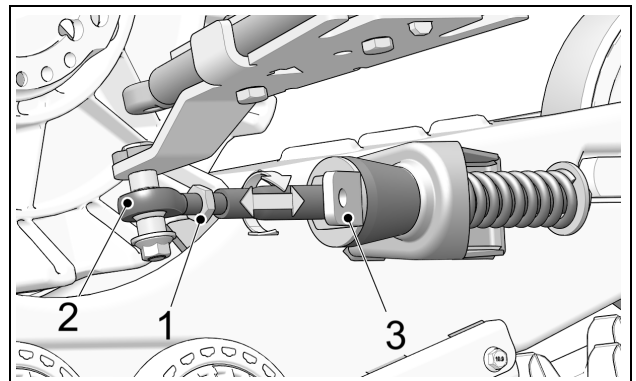

Figure 5

- When angle of attack is correctly set, tighten the jam nut (1) back against the stabilizing arm to 40 N·m [30lb·ft] of torque. See Figure 6.

CAUTION: Follow the recommended torque when tightening the jam nut. Over-tightening the nut might damage the rod end.

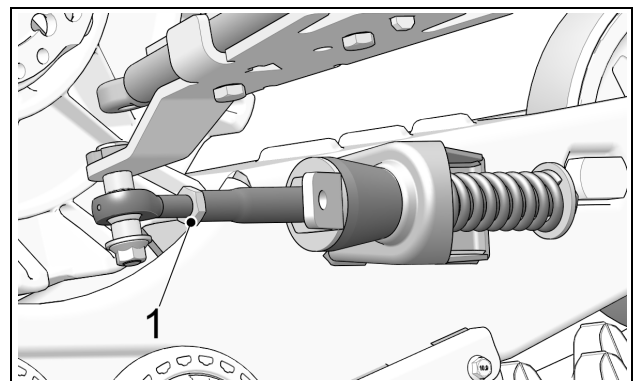

Figure 6

- Once the centered bubble in the level indicates that the angle of attack is correct, double-check the setting by validating the distance from the top of the back tires to the ground. Figure 7.

- Position a flat bar on top of the rear wheels of the front Track System and measure from the ground up to the flat bar as shown on Figure 7.

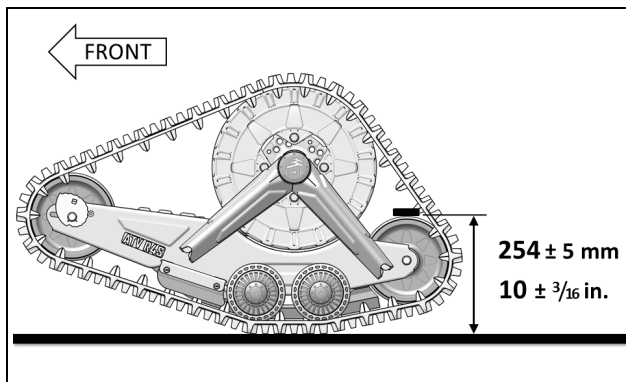

Figure 7

CAUTION: The 254 mm dimension corresponds to the required angle of attack setting. If the centered bubble in the level does not produce the required measurement of 254 mm, re-adjust angle of attack to obtain the required dimension without referring to the bubble level.

NOTE: Once angle of attack adjustment on front systems is completed, verify once more to confirm adjustment setting.

BASIC TUNING (Front Track Systems)

- An adjustment of more than **254 mm [10 in]**, measured with the flat bar, provides easier steering but produces a wobbling effect at high speed.
- An adjustment of less than **254 mm [10 in]**, measured with the flat bar, results in harder steering and more stability at high speed.

ANGLE OF ATTACK - REAR SYSTEMS

To obtain the correct angle of attack on rear Track Systems, perform the following:

RIGID AXLE OR TRAILING ARM SUSPENSION

CAUTION: Some vehicles require a particular adjustment. Refer to the *Installation Guidelines* specific to your vehicle model to confirm the adjustment.

- Stabilizing arm (1) must be attached to Track System and to rear anchor bracket (2) installed on vehicle. See Figure 8.

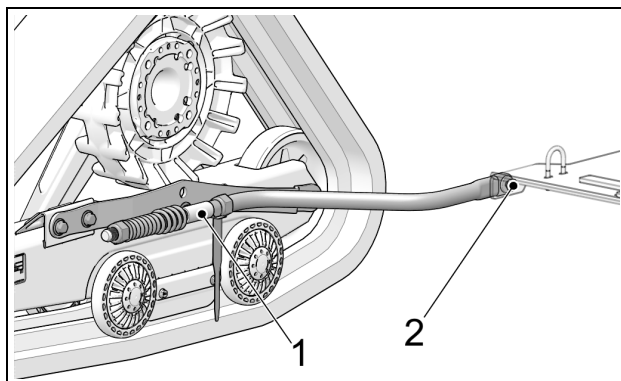

Figure 8

- Loosen nut (3) compressing stabilizing rod spring. See Figure 9.

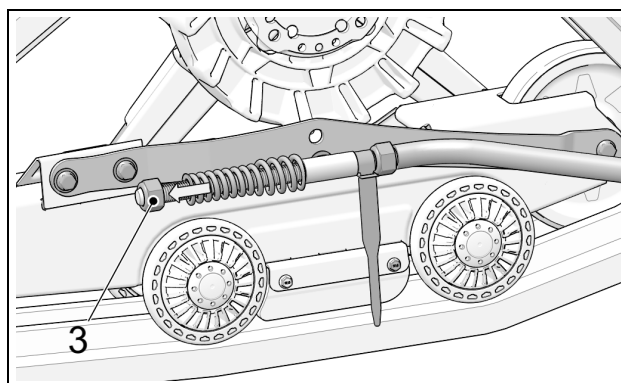

Figure 9

NOTE: Use narrow part of adjusting template provided with stabilizing arm to make adjustment.

- Set nut (4) to obtain a distance of 10 mm between nut and stabilizing arm guide as shown on Figure 10.

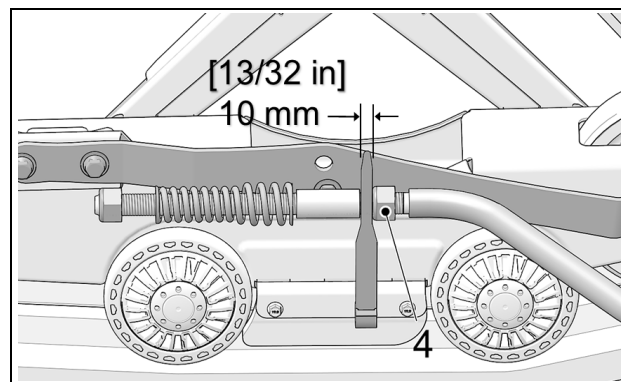

Figure 10

- Turn nut (3) until it comes in contact with spring, then compress spring by turning nut 1 1/2 turn. See Figure 11.

ADJUSTMENTS

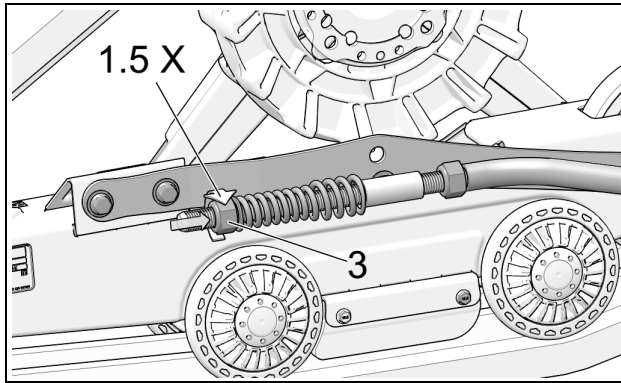

Figure 11

- **IMPORTANT:** Double-check the 10 mm minimum distance between nut and stabilizing arm guide. Re-adjust as needed. Figure 12.

NOTE: Use the provided template to double-check the adjustment.

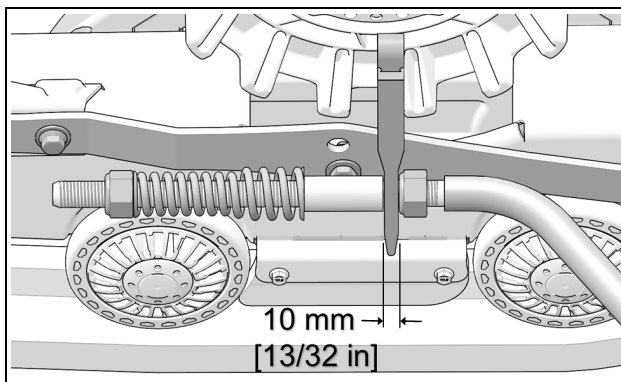

Figure 12

INDEPENDENT SUSPENSION (IS)

- Stabilizing arm (1) must be attached to rear anchor bracket (2) installed on vehicle. Figure 13.

NOTE: Actual Rear Anchor bracket (2) mounted on vehicle may differ from the one in the illustration.

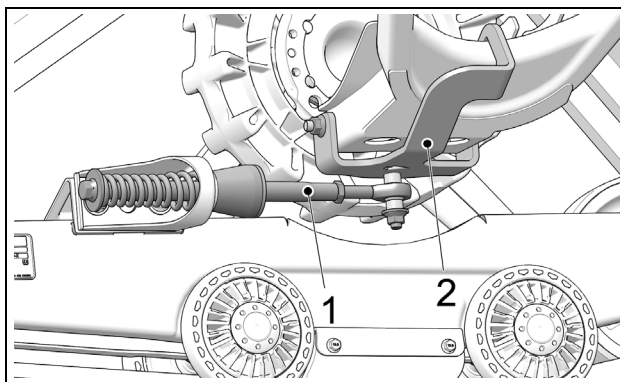

Figure 13

- Loosen jam nut (1). Turn stabilizing arm (3) to adjust length of rod end (2) so that rubber cone (4) applies light pressure on anti-rotation retainer (5). Figure 14.

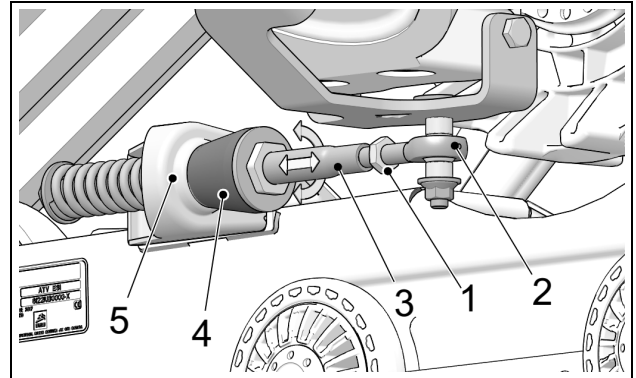

Figure 14

- Re-tighten jam nut (1) to 40 N•m [30 lb-ft] of torque when adjustment is complete. Figure 15.

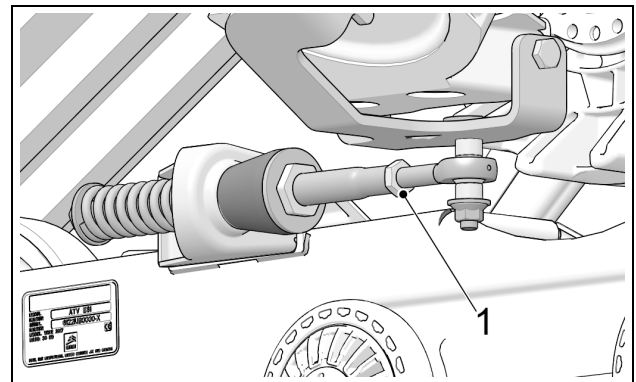

Figure 15

CAUTION: Tighten the jam nut to the recommended torque specification. Over-tightening the nut might damage the rod end.

NOTE: Once angle of attack adjustment on rear systems is completed, verify once more to confirm adjustment setting.

BASIC TUNING (Rear Track Systems):

- The adjustment is **incorrect** when the stabilizing arm's rubber cone is compressed and deformed. The stabilizing arm's spring is then difficult or impossible to turn by hand.

TRACK SYSTEM REMOVAL

CAUTION: Leaving the anti-rotation anchor brackets attached to the suspension arms, after having removed the Track Systems, could cause interference which might damage the vehicle. Remove all Track System anti-rotation components installed on the vehicle before reinstalling the wheels.

ALIGNMENT

Parallelism must be adjusted with the ATV on the ground, driving the vehicle forward about 3 meters [10 ft.] and measuring toe-in distance. Refer to Figure 16.

NOTE: Every time the measurement has to be taken, drive in reverse, then, drive forward again for about 3 meters [10 ft.].

CAUTION: Verify condition of the steering system components before adjusting parallelism. Damaged components can prevent proper adjustment and impair proper operation of the system.

CAUTION: Parallelism adjustment of front Track Systems is very important and is directly linked to longevity of System components. Users must follow attentively the adjustment and verification recommendations of this manual.

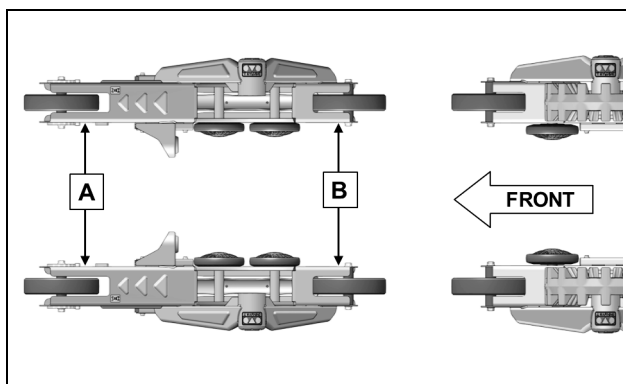

Figure 16

Dimension A: inside distance between front system frames at front wheels.

Dimension B: inside distance between front system frames at rear wheels.

Dimension A must be equal to or greater than **dimension B** without exceeding **3 mm [1/8 inch]**.

A - B = 0 to 3 mm [1/8 inch]

Adjustment Method

To adjust the ATV's steering system, first loosen coupling rod nuts (1), then screw or unscrew the coupling rod (2) an equal number of revolutions on both sides of the vehicle. Re-tighten nuts when adjustment is complete. See Figure 17.

NOTE: Starting with an open alignment setting provides a higher degree of precision in the adjustment.

CAUTION: Remember that some nuts have reverse threads before loosening a coupling rod nuts (1) on the vehicle's steering system. Make sure to unlock the nut in the proper rotational direction.

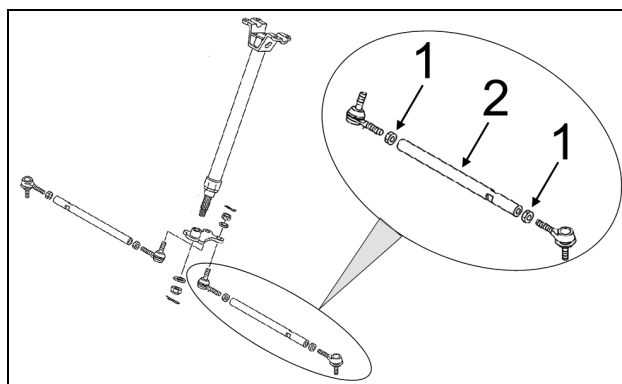

Figure 17

NOTE: Once parallelism of front Track Systems is set, verify once more to confirm adjustment setting.

ADJUSTMENTS

Measure A: Measure the distance inside the front ends of the front Track System frames. See Figures 18, 19 and 20.

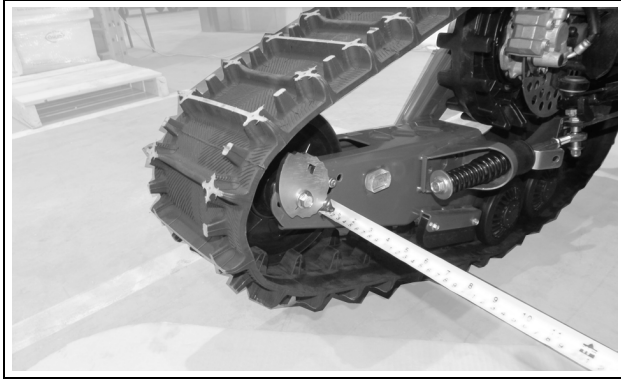

Figure 18



Figure 19 (Distance inside front frames - front end)

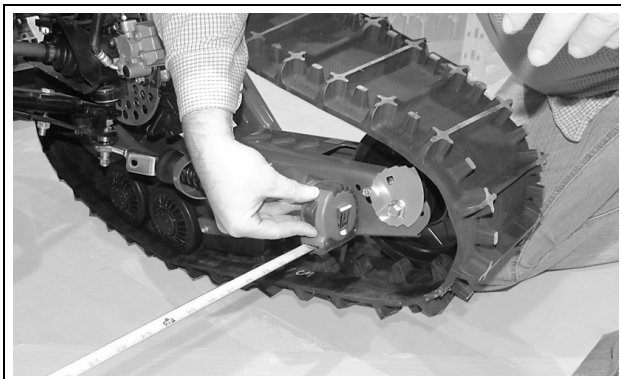

Figure 20

Measure B: Measure the distance inside the rear ends of the front Track System frames. See Figures 21, 22 and 23.

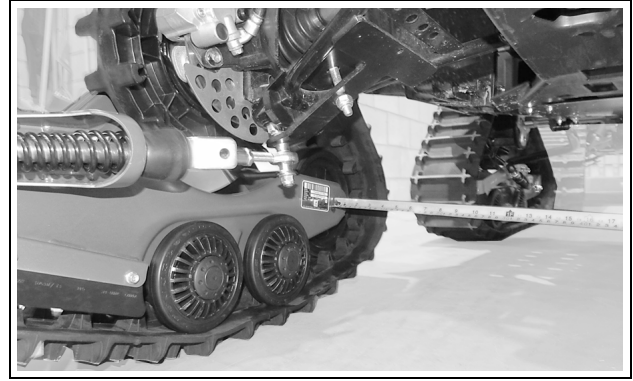

Figure 21

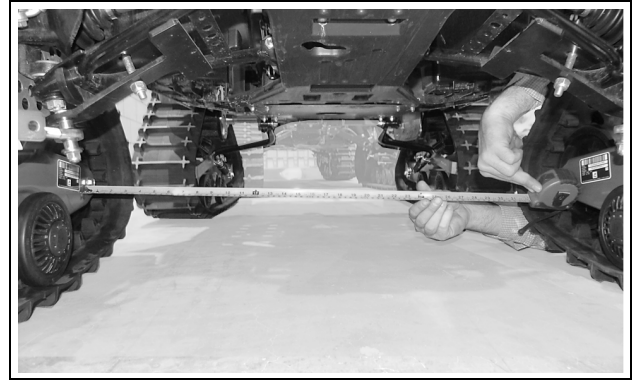

Figure 22 (Distance inside front frames - rear end)



Figure 23

TRACK TENSION

- Loosen both tensioner side wheel shaft bolts (1), enough to allow tensioner cams (2) to turn. Figure 24.

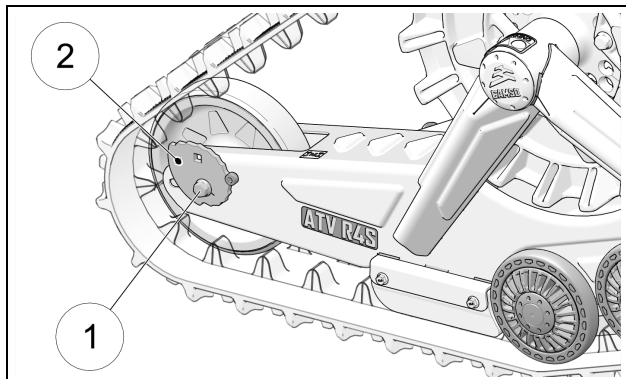

Figure 24

- Insert ratchet wrench extension with 3/8" drive (1) in tensioner cam's square hole. Figure 25.

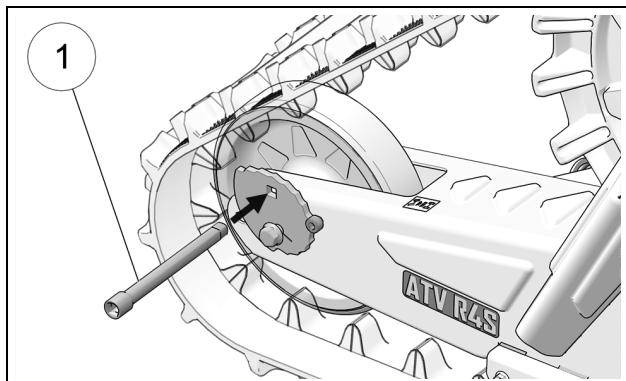

Figure 25

- Turn cam on each side and adjust tension as close as possible to the recommended tension. Figure 26.

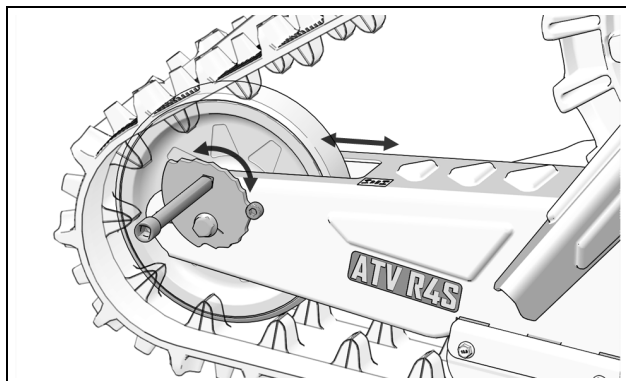

Figure 26

CAUTION: Tensioner cam adjustment position must be identical on both sides of Track System. Verify adjustment by counting at which position each cam is set. Both positions must be the same.

- After having adjusted the tension and **verified cam positions**, re-tighten both wheel shaft bolts to 50 N-m (37 lb-ft) of torque.
- Position of Tensioner cam locking bolts:
 - (A) - System with 15 or 16-tooth sprockets.
 - (B) - System with 17 or 18-tooth sprockets. See Figure 27.

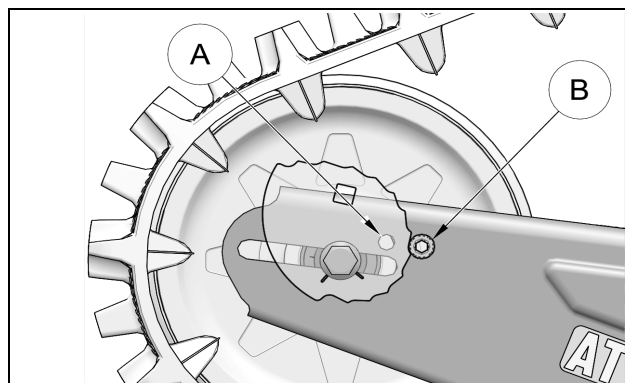

Figure 27

- Installation direction of Tensioner cams. Figure 29 and Figure 29.

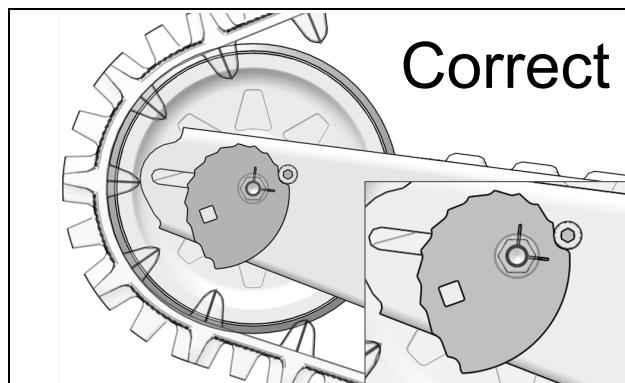

Figure 28

NOTE: With tensioner cam in position 0, the small slots cut at 90° should indicate 3 o'clock.

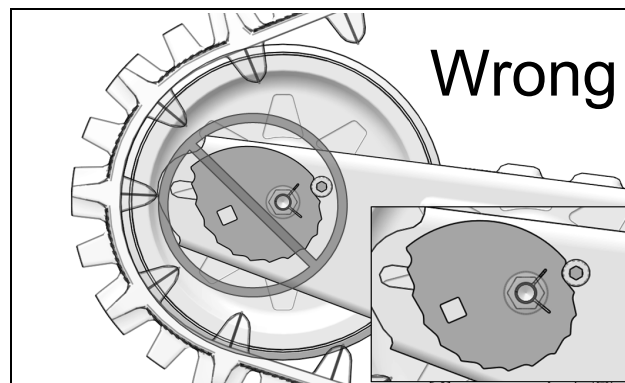

Figure 29

ADJUSTMENTS

The table below shows the force (1) applied and the deflection (2) which must occur to correctly set track tension. Refer also to Figure 31.

TRACK	FORCE	DEFLECTION
Front	13,5 kg (30 lb)	17 mm ($\frac{5}{8}$ in.)
Rear	13,5 kg (30 lb)	17 mm ($\frac{5}{8}$ in.)

BASIC TUNING

- Higher rubber track tension reduces the risk of “derailing” and reduces drive “ratcheting”.

NOTE: Track tension set too high could cause premature wear on system components and is therefore not recommended.

- Lower rubber track tension provides better traction, a smoother ride and better fuel economy.

NOTE: The track tension testing tool shown below in Figure 30 can be purchased through an authorized Camso dealer. Part #2000-00-3125.



Figure 30

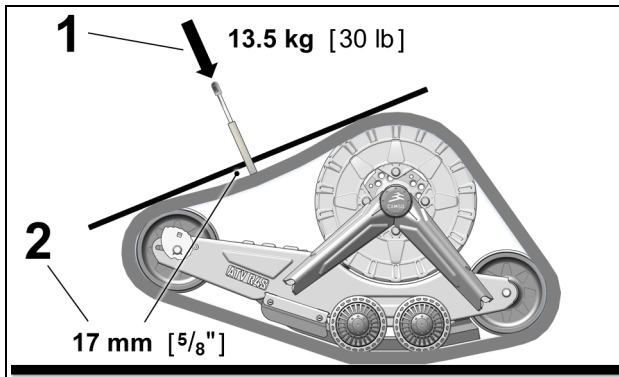

Figure 31

Final Check

Ride at slow speed on a distance of about 1.5 km [1 mile]. Re-adjust as required.

**CAMSO ATV R4S TRACK SYSTEMS
INSTALLATION AND ADJUSTMENT CHECKLIST**

**** Steps in this checklist are laid out in logical order. They should be performed in succession to optimize the track system installation on the vehicle. ****

1 - COMPONENT INSTALLATION

✓

A - INSTALLATION OF REAR ANCHOR BRACKETS

** Refer to INSTALLATION GUIDELINES section entitled "Rear track systems"*

B - INSTALLATION OF FRONT ANCHOR BRACKETS

** Refer to INSTALLATION GUIDELINES section entitled "Front track systems"*

C - INSTALLATION OF STEERING LIMITERS (if applicable)

** Refer to INSTALLATION GUIDELINES section entitled "Front track systems" . ** Do not adjust the Steering Limiter sets before having adjusted the angle of attack.*

2 - COMPONENT ADJUSTMENT

A - ANGLE OF ATTACK

** Refer to ADJUSTMENTS section entitled "Angle of attack"*

B - TRACK ALIGNMENT

** Refer to ADJUSTMENTS section entitled "Track alignment"*

C - TRACK TENSION

** Refer to ADJUSTMENTS section entitled "Track tension"*

D - STEERING LIMITER ADJUSTMENT (if applicable)

** Refer to INSTALLATION GUIDELINES section entitled "Front track systems"*

3 - INTERFERENCE CHECK

IN THE EVENT OF INTERFERENCE BETWEEN THE VEHICLE AND TRACK SYSTEM, SOME PARTS ON THE VEHICLE MAY HAVE TO BE REMOVED OR MODIFIED, OR A LIFT KIT MAY HAVE TO BE INSTALLED. IF APPLICABLE, SEE INSTALLATION GUIDELINES SECTION ENTITLED "COMPLETION".

4 - TEST RUN

1.5 km (1 mile) TEST RUN

5 - POST TEST RUN FINAL CHECKS

A - ANGLE OF ATTACK

** Refer to ADJUSTMENTS section entitled "Angle of attack"*

B - TRACK ALIGNMENT

** Refer to ADJUSTMENTS section entitled "Track alignment"*

C - TRACK TENSION

** Refer to ADJUSTMENTS section entitled "Track tension"*